

PRESTO-TITE EXTENDED CANTED FASCIA

EXISTING BEVELED WOOD NAILER VERSION

INSTALLATION INSTRUCTIONS

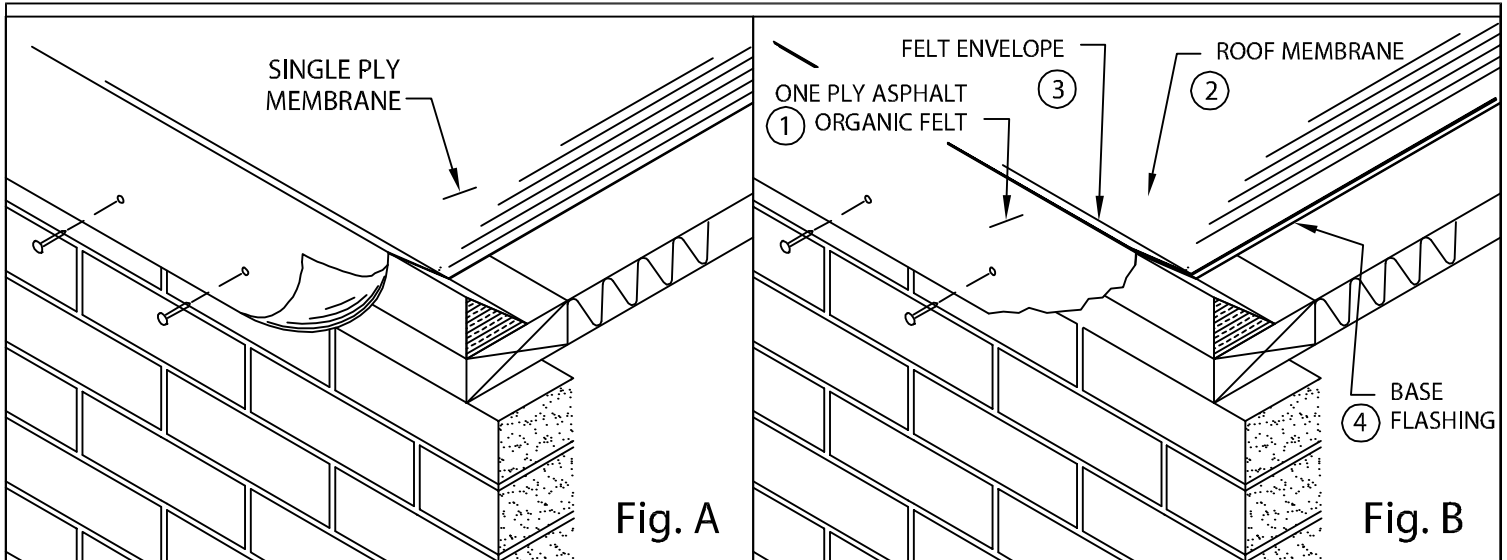

1. TYPICAL ROOFING MEMBRANE APPLICATION

IN SINGLE PLY APPLICATION (FIG. A) A SINGLE LAYER OF ROOFING MATERIAL IS APPLIED OVER THE CANT BLOCK AND EXTENDING OVER THE FRONT FACE OF NAILER MAKING SURE NAILER IS COVERED. IN BUILT-UP OR MODIFIED APPLICATIONS (FIG. B) FIRST LAYER OF ROOFING IS EXTENDED OVER THE FACE OF THE NAILER AND THE FLASHING MATERIAL IS TO EXTEND UP THE CANT BLOCK UNDER THE EXTRUDED ANCHOR BAR.

NOTE : FOLLOW GENERAL RECOMMENDATIONS OF THE ROOF MEMBRANE MANUFACTURERS APPLICATION OF MATERIALS OVER THE ROOF EDGE.

CAUTION : INSTALLERS SHALL WEAR PROTECTIVE EYEWEAR TO PREVENT SERIOUS INJURY.

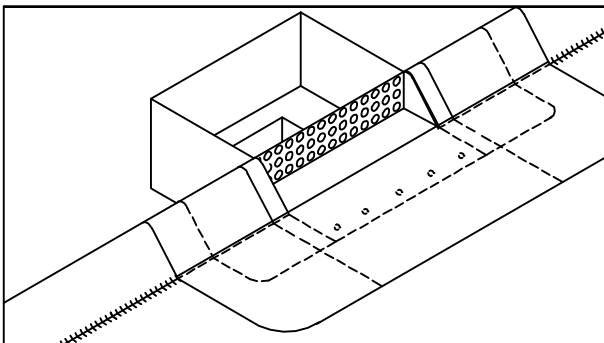

2. SCUPPERS

INSTALL SPILLOUT OR DOWNSPOUT SCUPPERS (IF APPLICABLE) AT PREDETERMINED LOCATIONS.

NOTE : ROOF MEMBRANE IS INSTALLED UNDER SCUPPER. SCUPPER FLANGE IS SET IN A CONTINUOUS BEAD OF NON-CURING SEALANT.

NOTE : FOLLOW GENERAL RECOMMENDATIONS OF THE ROOF MEMBRANE MANUFACTURERS APPLICATION ON STRIPPING IN THE SCUPPER.

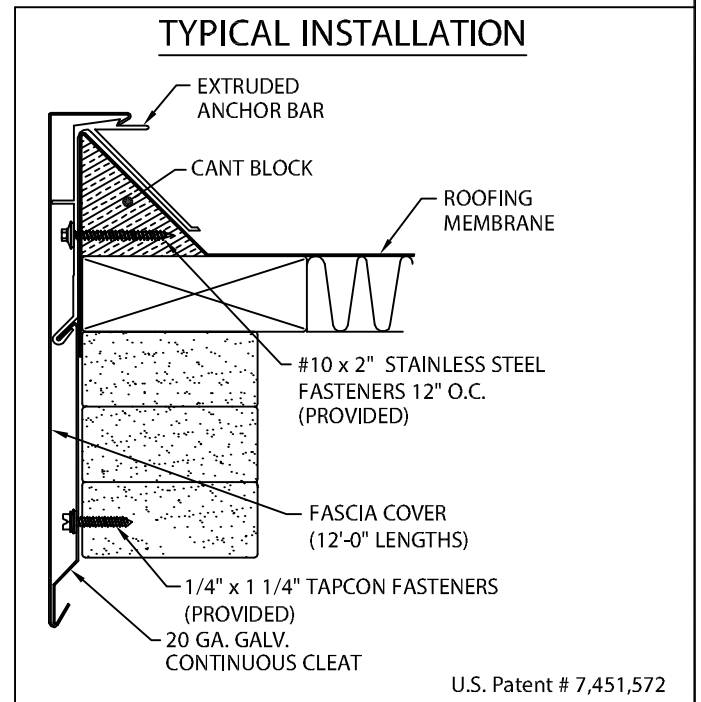

U.S. Patent # 7,451,572

PRESTO-TITE EXTENDED CANTED FASCIA

EXISTING BEVELED WOOD NAILER VERSION

INSTALLATION INSTRUCTIONS

IMPORTANT!
CLEAT MUST
BE HOOKED
INTO MITER
BAR BEFORE
INSTALLING!

#10 x 2" STAINLESS STL. SCREW
1/4" x 1 1/4"
WOOD/MASONRY SCREW

MITER CLEAT
FLUSH TO OUTSIDE
EDGE OF MITER BAR

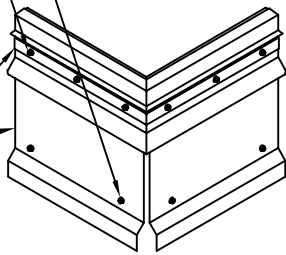

5. MITER BAR & MITER CLEAT INSTALLATION

HOOK MITER CLEAT PIECES TO MITER BAR. FLUSH ENDS OF MITER CLEAT PIECE AND MITER BAR. INSTALL MITER ASSEMBLY WITH ONE ANCHOR BAR SPLICE PLATE UNDER EACH END OF MITER BAR. FASTEN THE MITER BAR USING 2" HEX HEAD STAINLESS STEEL FASTENERS. FASTENERS AND DRIVE BITS PROVIDED. NEXT LOCATE AND INSTALL THE SPILLOUTS AND SCUPPERS WITH FASTENERS AND SPLICE PLATES.

6. ANCHOR BAR & CLEAT INSTALLATION

HOOK ANCHOR CLEAT TO ANCHOR BAR AS SHOWN IN STEP 4. POSITION 12'-0" ANCHOR BAR/CLEAT SECTIONS OVERLAPPING BAR SPLICE PLATE. ALLOW 3/8" SPACE BETWEEN ANCHOR BARS. INSTALL BAR SPLICE PLATE AT OTHER END OF BAR/CLEAT SECTION. FASTEN ANCHOR BAR 12" O.C. THROUGH THE SLOTTED HOLES USING PROVIDED 2" FASTENERS. FASTEN ANCHOR CLEAT 24" O.C. THROUGH SLOTTED HOLES USING PROVIDED 1 1/4" FASTENERS. FIELD CUT SECTIONS AS IS NECESSARY.

7. FASCIA MITERS COVERS

INSTALL MITER COVERS FIRST. INSERT ONE SPLICE PLATE UNDER EACH END OF THE TWO PIECE MITER COVER. ENGAGE COVER WITH 90° TAB ONTO BOTTOM OF ANCHOR BAR AND ROTATE MITER COVER UP AND OVER ANCHOR BAR MITER UNTIL ENGAGED ALONG ENTIRE LENGTH OF THE ANCHOR BAR. REPEAT STEPS TO INSTALL MITER COVER WITHOUT THE 90° TAB.

8. FASCIA COVERS

INSTALL 12'-0" FASCIA COVER SECTIONS. ALLOW A 3/8" GAP BETWEEN FASCIA COVER SECTIONS. INSERT ONE SPLICE PLATE UNDER FAR END OF EACH FASCIA COVER SECTION. INSTALL COVER BY HOOKING LOWER EDGE OF COVER ONTO ANCHOR CLEAT AND ROTATING UP AND OVER ANCHOR BAR UNTIL ENGAGED ALONG ENTIRE LENGTH OF COVER SECTION. CONTINUE TO INSTALL COVER SECTIONS IN THIS MANNER, FIELD CUTTING WHERE NECESSARY USING A FINE TOOTH HACKSAW.

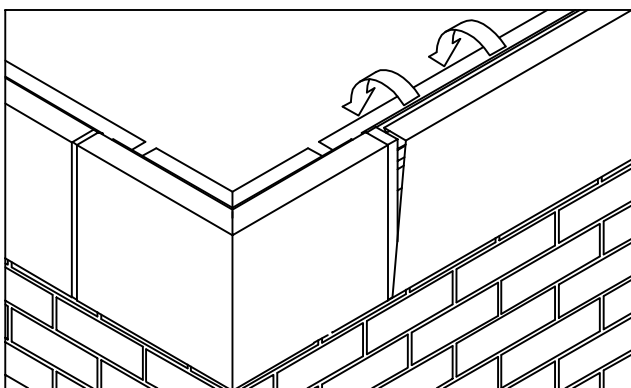
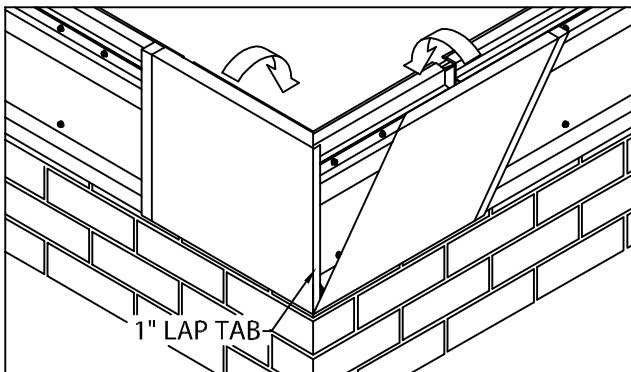
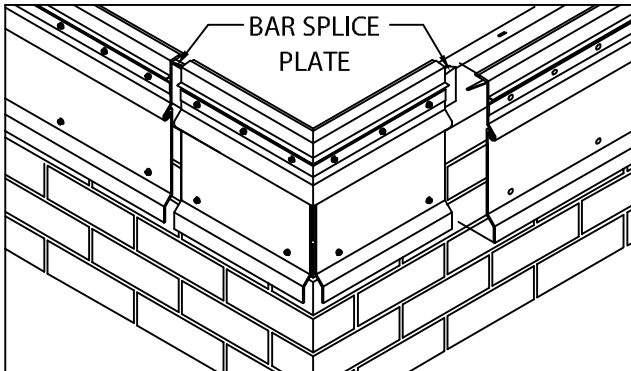

IMPORTANT !

BE SURE TO REMOVE PROTECTIVE FILM
PRIOR TO INSTALLING EACH FASCIA SECTION.

JM Johns Manville

USA: 800-223-8317
Canada: 800-445-1500

DATE: 12/15/16

DRN BY: JJC

CKD BY: SAK

SHT.# 2 OF 2

DWG# 16110-2561

G