

DERBIGUM PERMA-TITE QUICKLOCK RADIUS COPING

TAPERED VERSION

IMPORTANT!!! MUST INDICATE PROPER RADIUS CONDITION BY CIRCLING APPROPRIATE OUTSIDE FACE

PROVIDING A RADIUS
THE RADIUS MAY BE PROVIDED
IN ONE OF TWO METHODS:

1.) THE ACTUAL KNOWN RADIUS IS

' FEET " INCHES MINIMUM OF 3'-0"

OR

2.) FIELD CONDITION MEASUREMENTS

NOTE: REFER TO ATTACHED WORKSHEET
FOR FURTHER INFORMATION

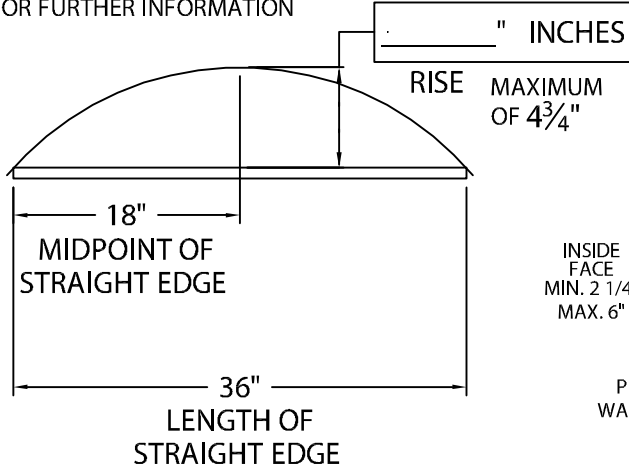

NOTE: CHECK MEASUREMENTS ALONG ENTIRE RADIUS.

DETAIL A

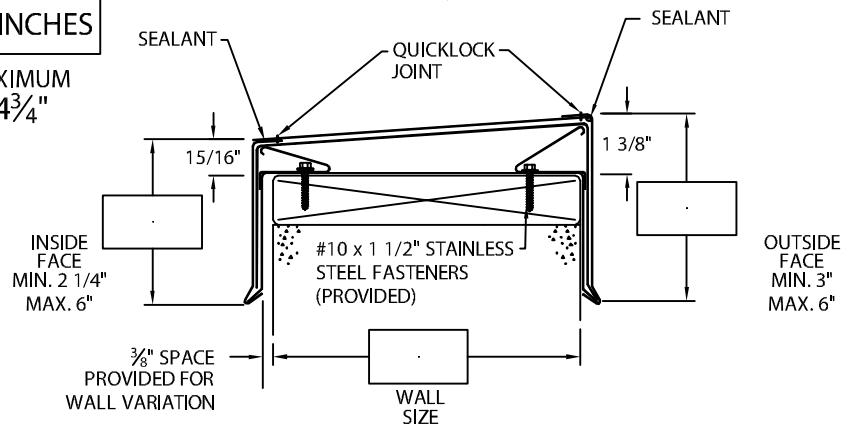
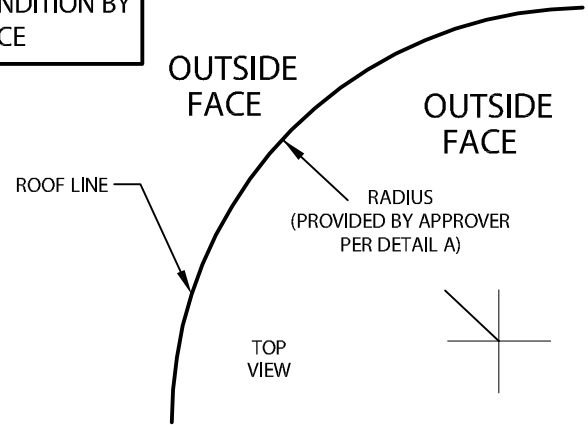

NOTES: -- Concealed splice plates are provided with factory applied dual non-curing sealant strips.
-- Fabrication of radius is furnished utilizing a non-penetrating quicklock joint, then factory sealed watertight.

MATERIAL:

- 24 Ga. Steel
- .040" Aluminum
- .050" Aluminum
- .063" Aluminum
- Other _____

Color: _____

Finish: _____

QUANTITIES:

_____ Lineal Feet 4'-0" Lengths

Fabrication will proceed only after receipt of signed print approval.

Print Approval:

Architect and/or contractor shall verify all dimensions, sizes and quantities. All products to be installed in strict accordance with Derbigum's printed instructions.

Approved by: _____

Date: _____

PROJECT:

ARCHITECT:

ROOFING CONTRACTOR:

REPRESENTATIVE/DISTRIBUTOR:

Customer Service
1-800-727-9872



DATE: 02/11/17

DRN BY: JJC

CKD BY: SAK

SHT.# ____ OF ____

DWG# 20011-25671

A