



FLEXLOCK FLT ROOF EDGE

FULLY ADHERED OR MECHANICALLY ATTACHED SINGLE-PLY VERSION

SPLICE PLATE VERSION INSTALLATION INSTRUCTIONS

FOR RADIUS INSTALLATION INSTRUCTIONS SEE PAGE 5 & 6

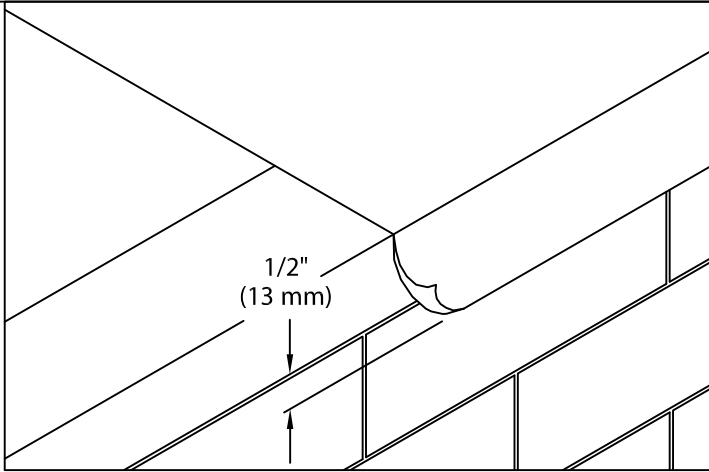

1. Roof Membrane

Position membrane over the roof edge and down outside face of wall, covering wood nailer(s) completely. Allow 1/2" excess membrane.

IMPORTANT! Outside edge of treated wood nailer(s) (minimum 2 x 4) shall be aligned flush with or extend slightly past outermost edge of wall. Flexlock FLT Roof Edge is for use as a perimeter securement on roof designs where the product is not installed in a waterline. If the product will be in a waterline or requires drainage over the edge, we would recommend the use of Flexlock FLE Canted Fascia or Flexlock Drip Edge, depending on desired retention of water or drainage.

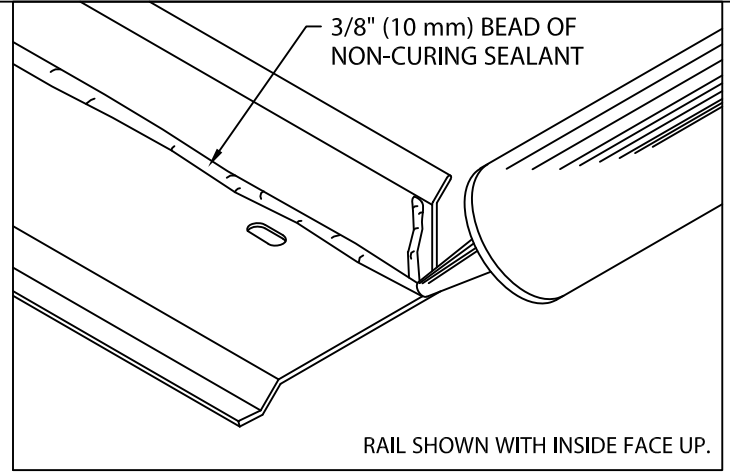

2. Miter & Scupper Base Rail (Preparation)

Lay miters and spillover scuppers on deck with outside face down. Be sure aluminum base rail is clean and free of dirt or dust. Apply a heavy 3/8" bead of non-curing sealant to the right angle intersection of the deck flange and back of base rail as shown. Application of sealant is required along the full length of each miter base rail. Apply a similar 3/8" bead of mastic to the flange's left end, as you look at the outside face of the rail section.

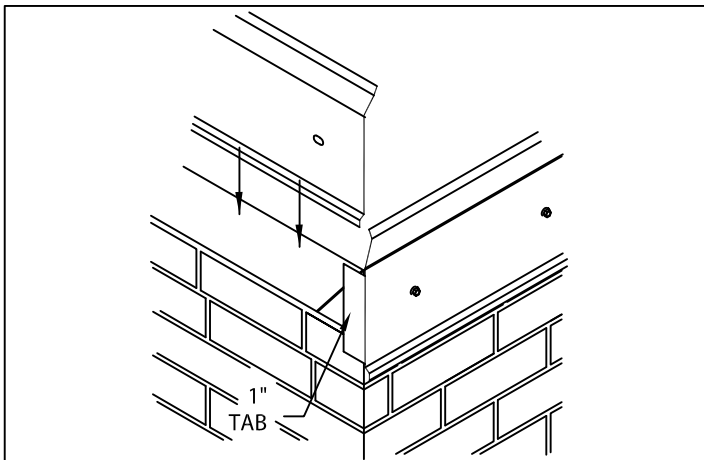

3. Base Rail Miter Installation

See sheet 4 for miter fabrication. Fold roofing membrane at corners and install miters using fasteners and driver bit provided by Versico. Next locate and install spillouts and scuppers with mastic & fasteners.

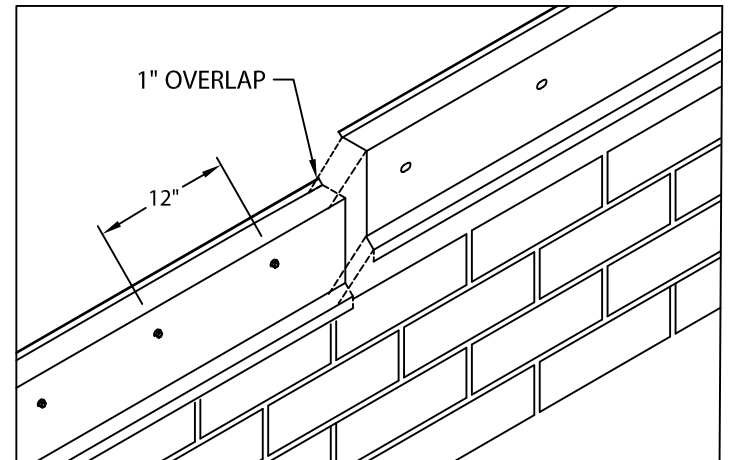

4. Base Rail Installation

Install 12'-0" sections of base rail from right to left as seen from roof top, lapping the previous section 1". Fasten base rail to nailer(s) through base rail slots 12" o.c. with provided fasteners. Field cut the base rail sections as needed.



Customer Service
Phone: 800-969-0108
Fax: 610-916-9501

DATE: 09/12/19
DRN BY: ZS
CKD BY: JAI

SHT.# 1 OF 6
DWG# 28110-11796 **F**



FLEXLOCK FLT ROOF EDGE

FULLY ADHERED OR MECHANICALLY ATTACHED SINGLE-PLY VERSION

SPLICE PLATE INSTALLATION INSTRUCTIONS

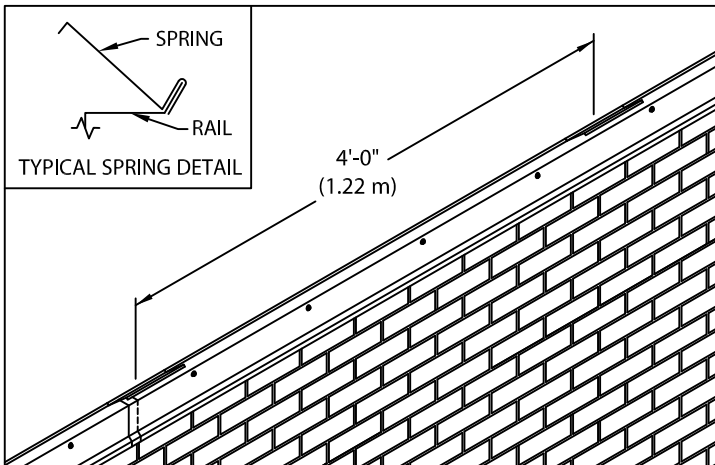

5. Spring Clips

Position 6" wide stainless steel spring clips at 4'-0" O.C. ensuring a spring clip at each fascia cover ends.

IMPORTANT! Be sure to remove protective plastic film prior to installing each fascia section.

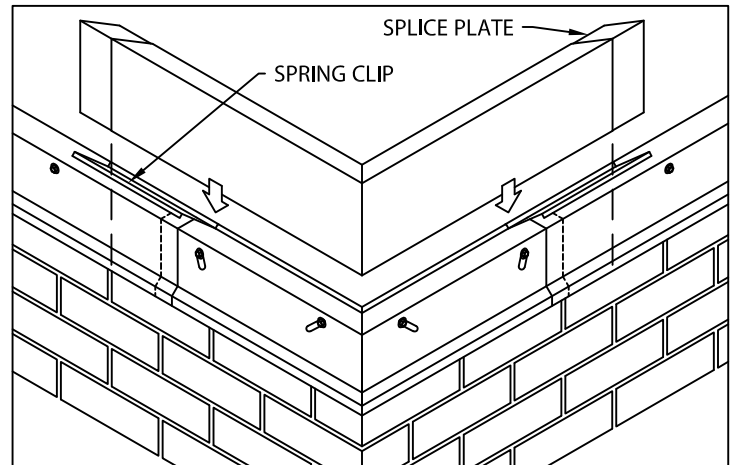

6. Fascia Miter Covers

Position 6" wide stainless steel spring at each end of fascia miter cover (2 total). Place splice plate into each end of miter cover. Remove protective film from miter covers. Simply position the cover above the rail and with palm of hand and apply slight pressure downward until engaged to the bottom of base rail.

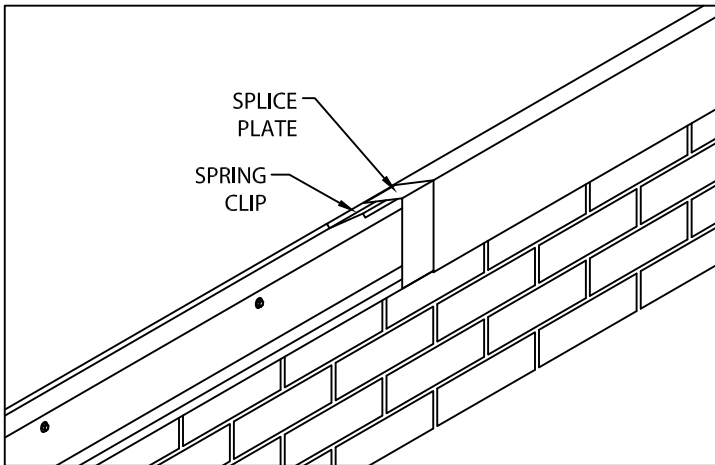

7. Splice Plates

Remove the protective film from fascia covers. Fascia covers shall be installed from left to right as seen from rooftop. Place splice plate in right end of cover. Position right cover of 12'-0" fascia on top of base rail. Snap cover onto base rail by applying downward pressure with palm of hand until the fascia cover is fully engaged along entire length to the rail's bottom. Field cut covers as required with fine tooth hacksaw.

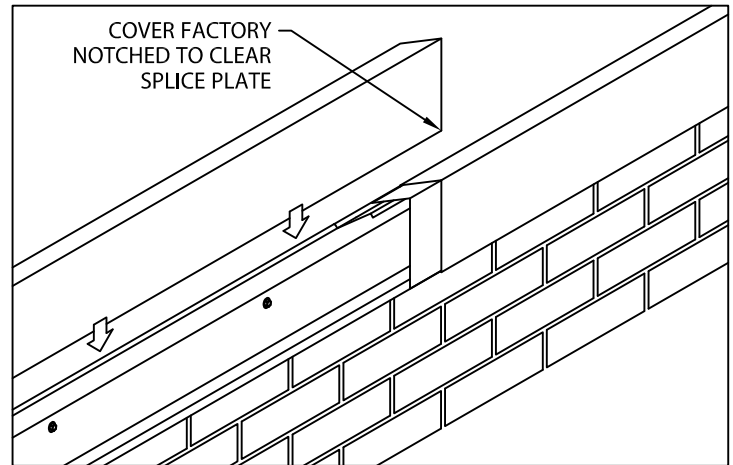

8. Fascia Covers

Position pre-notched cover and snap onto base rail by pressing down with the palm of your hand until the cover is fully engaged along the entire length. Allow 3/8" gap between cover sections. Field cut where necessary using a fine tooth hacksaw.



Customer Service
Phone: 800-969-0108
Fax: 610-916-9501

DATE: 09/12/19
DRN BY: ZS
CKD BY: JAI

SHT.# 2 OF 6
DWG# 28110-11796

F



FLEXLOCK FLT ROOF EDGE

FULLY ADHERED OR MECHANICALLY ATTACHED SINGLE-PLY VERSION

SPLICE PLATE VERSION INSTALLATION INSTRUCTIONS

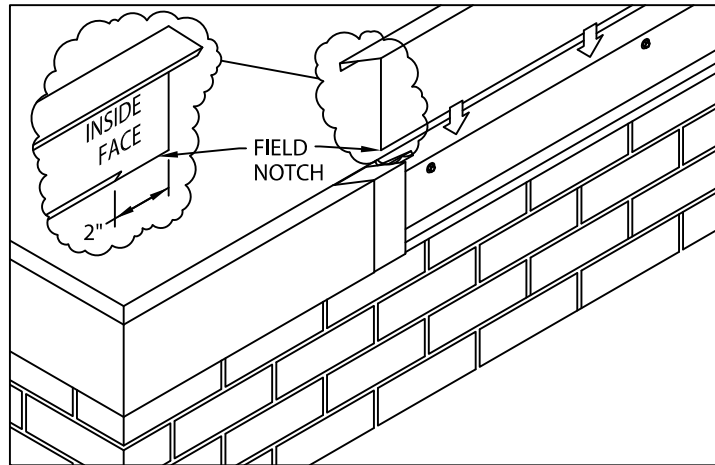

9. Fascia Covers at Miter

At miter, field notch right side of cover as shown. Snap onto base rail by applying downward pressure with palm of hand until the fascia cover is fully engaged along entire length of the rail's bottom. Allow 3/8" gap between cover sections. Field cut covers as required with fine tooth hacksaw.

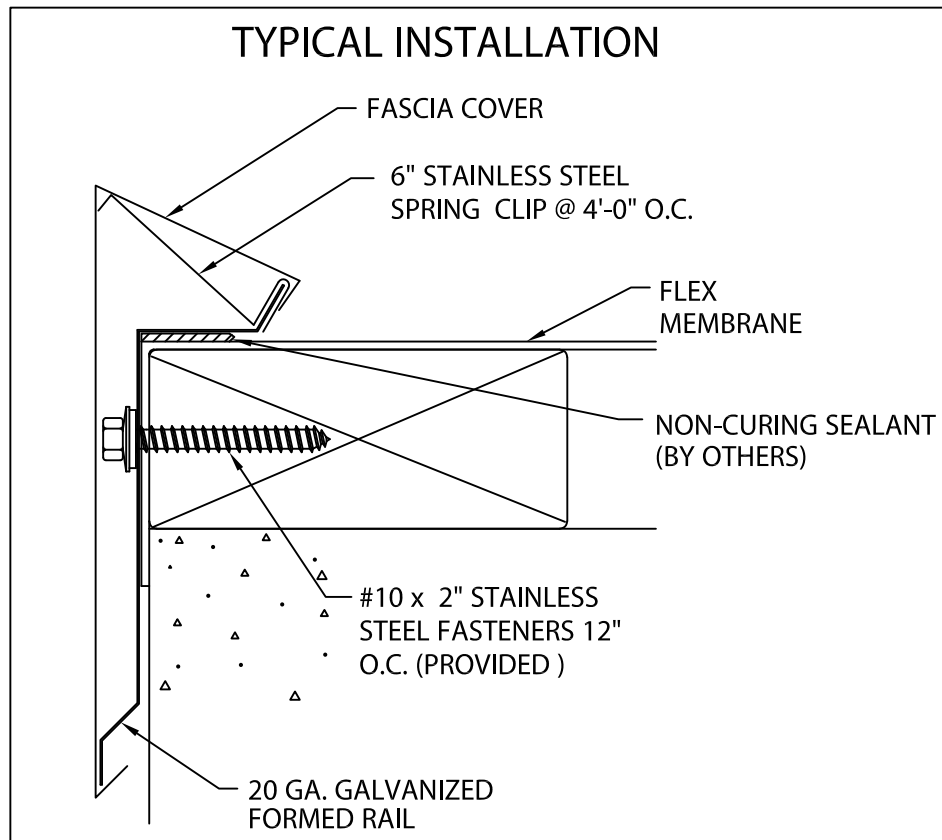

U.S. Patent # 5,927,023



Customer Service
Phone: 800-969-0108
Fax: 610-916-9501

DATE: 09/12/19
DRN BY: ZS
CKD BY: JAI

SHT.# 3 OF 6
DWG# 28110-11796

F



FLEXLOCK FLT ROOF EDGE

FULLY ADHERED OR MECHANICALLY ATTACHED SINGLE-PLY VERSION

SPLICE PLATE VERSION INSTALLATION INSTRUCTIONS

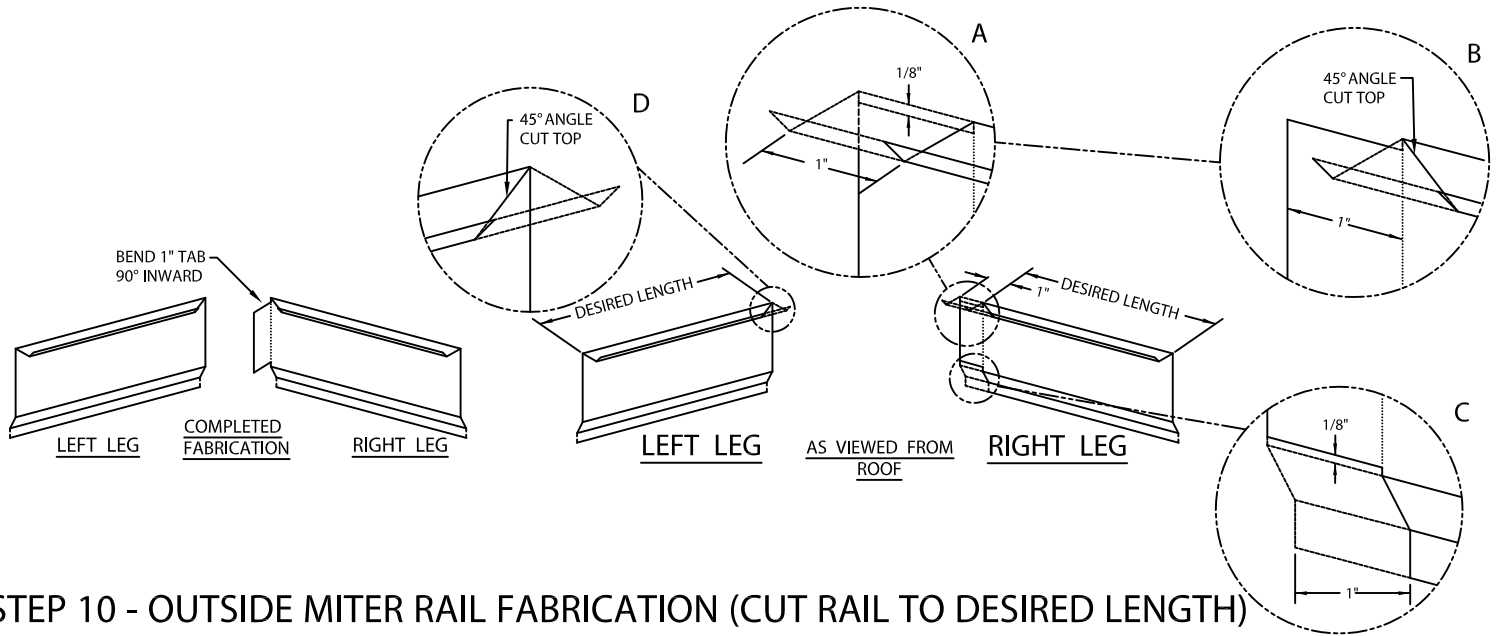

STEP 10 - OUTSIDE MITER RAIL FABRICATION (CUT RAIL TO DESIRED LENGTH)

RIGHT LEG - DETAIL A: FIRST REMOVE A 1" SECTION FROM TOP FLANGE, 1/8" DOWN FACE AND 1" HORIZONTALLY AS SHOWN TO CREATE TAB. DETAIL B: CUT TOP FLANGE AT A 45° ANGLE. DETAIL C: CUT OFF BOTTOM FACE 1/8" x 1" AS SHOWN AND CONTINUE THROUGH AREA SHOWN ON BOTTOM FLANGE. BEND TAB INWARDS 90°. LEFT LEG - DETAIL D: TRIM TOP FLANGE AT A 45° ANGLE.

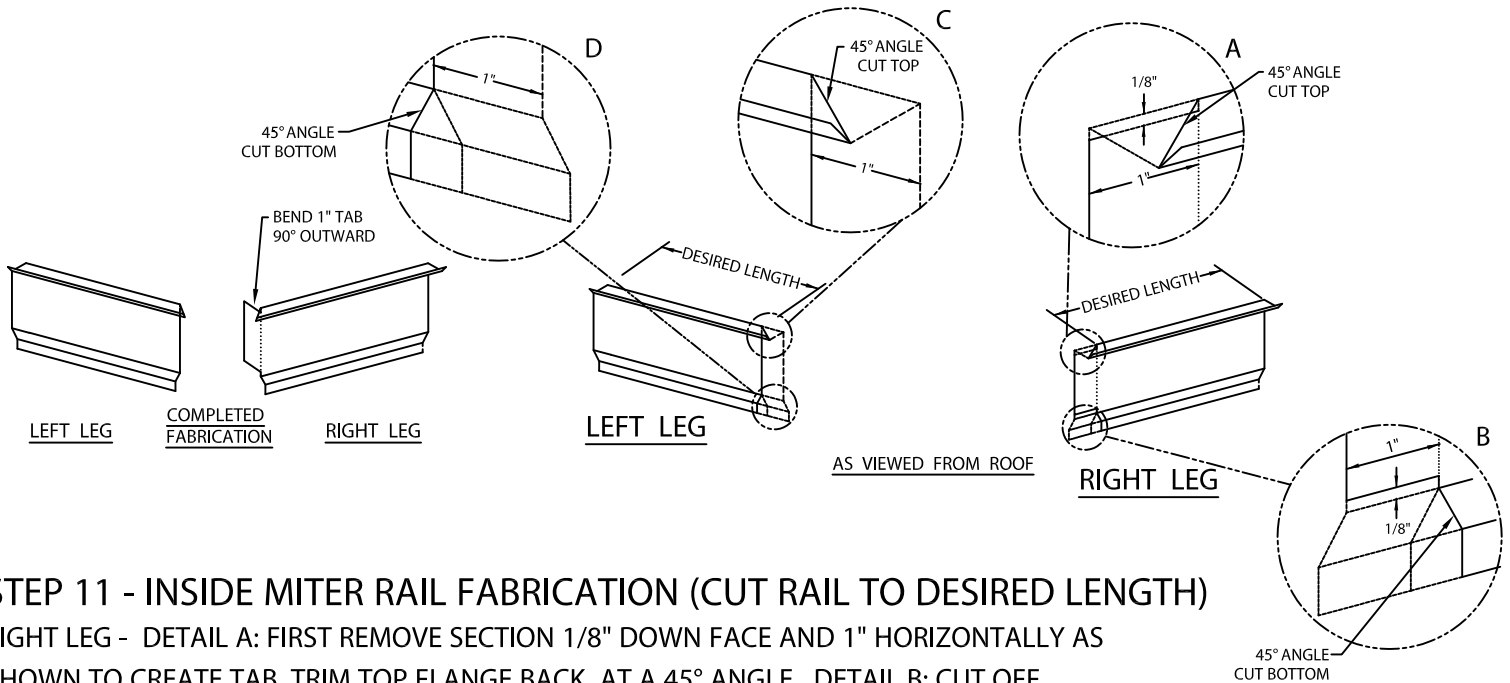

STEP 11 - INSIDE MITER RAIL FABRICATION (CUT RAIL TO DESIRED LENGTH)

RIGHT LEG - DETAIL A: FIRST REMOVE SECTION 1/8" DOWN FACE AND 1" HORIZONTALLY AS SHOWN TO CREATE TAB. TRIM TOP FLANGE BACK AT A 45° ANGLE. DETAIL B: CUT OFF BOTTOM FACE 1/8" AS SHOWN AND CONTINUE CUT AT A 45° THROUGH AREA SHOWN ON BOTTOM FLANGE. BEND TAB INWARDS 90°. LEFT LEG - DETAIL C: CUT TOP FLANGE AT A 45° ANGLE. CONTINUE DOWN FACE. DETAIL D: CUT BOTTOM FLANGE AT 45° ANGLE AS SHOWN.



Customer Service
Phone: 800-969-0108
Fax: 610-916-9501

DATE: 09/12/19
DRN BY: ZS
CKD BY: JAI

SHT.# 4 OF 6
DWG# 28110-11796

F



FLEXLOCK FLT ROOF EDGE

FULLY ADHERED OR MECHANICALLY ATTACHED SINGLE-PLY VERSION

RADIUS INSTALLATION INSTRUCTIONS: SPLICE PLATE VERSION

RADIUS INSTALLATION INSTRUCTIONS

TYPICAL INSTALLATION

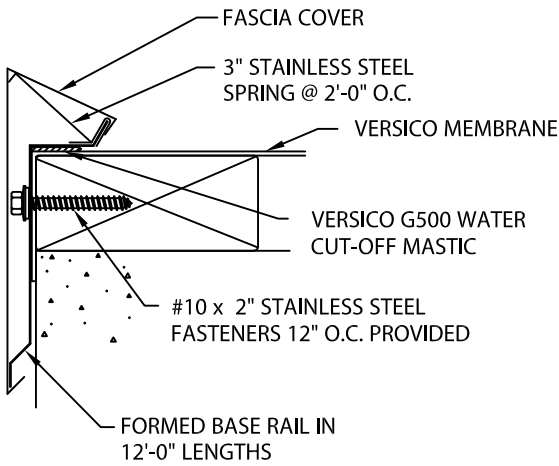

STEP 1

FOLLOW DIRECTIONS ON PAGE 1 FOR INSTALLING ROOF MEMBRANE & RAIL.

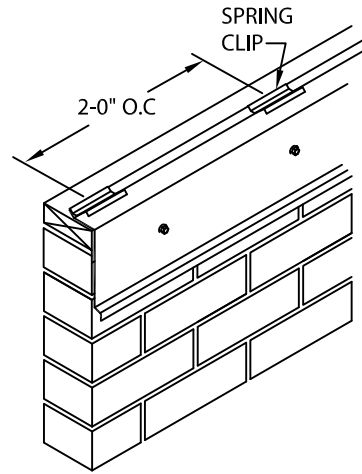

STEP 2 - SPRING CLIPS

LOCATE 3" WIDE SPRING CLIPS, STARTING WITH ONE AT THE END OF RAIL, THEN AT EVERY 2'-0" O.C., MAKING SURE THERE WILL BE A SPRING CLIP UNDER EACH FASCIA COVER END.

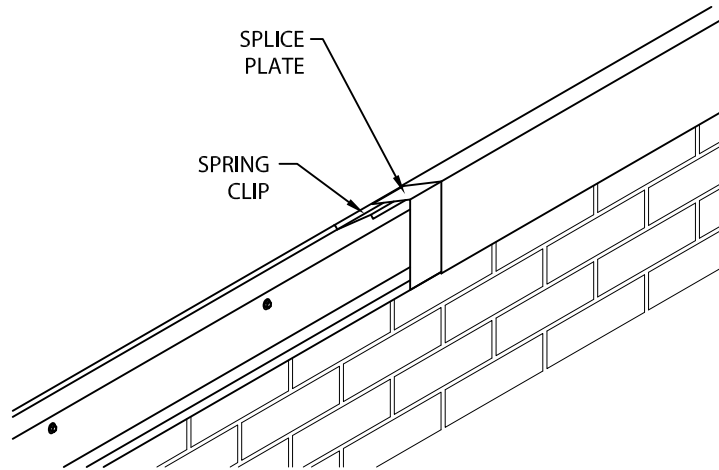

STEP 3 - SPLICE PLATES

REMOVE THE PROTECTIVE FILM FROM FASCIA COVERS. FASCIA COVERS SHALL BE INSTALLED FROM LEFT TO RIGHT (AS IN STEP 7 ON PAGE 2). PLACE SPLICE PLATE IN RIGHT END OF THE COVER. SNAP RIGHT COVER ONTO BASE RAIL BY APPLYING DOWNWARD PRESSURE WITH PALM OF HAND UNTIL THE FASCIA COVER IS FULLY ENGAGED ALONG ENTIRE LENGTH. FIELD CUT COVERS AS REQUIRED WITH FINE TOOTH HACKSAW.



Customer Service
Phone: 800-969-0108
Fax: 610-916-9501

DATE: 09/12/19
DRN BY: ZS
CKD BY: JAI

SHT.# 5 OF 6
DWG# 28110-11796

F



FLEXLOCK FLT ROOF EDGE

FULLY ADHERED OR MECHANICALLY ATTACHED SINGLE-PLY VERSION

RADIUS INSTALLATION INSTRUCTIONS: SPLICE PLATE VERSION

COVER FACTORY
NOTCHED TO CLEAR
SPLICE PLATE

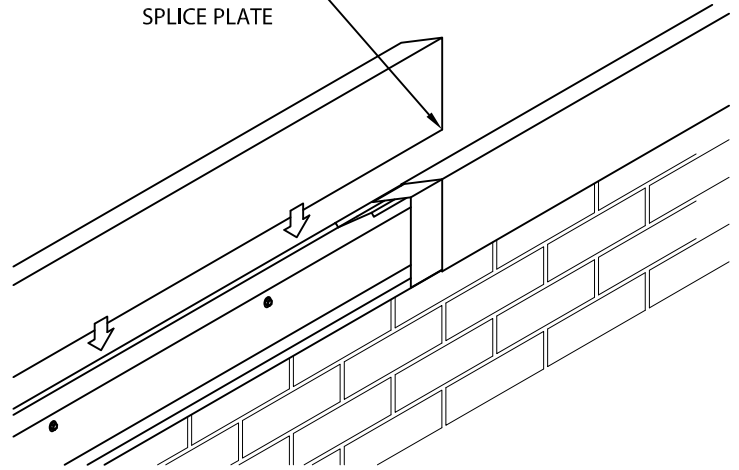

STEP 4 - FASCIA COVERS

POSITION PRE-NOTCHED COVER AND SNAP ONTO BASE RAIL BY PRESSING DOWN WITH THE PALM OF YOUR HAND UNTIL THE COVER IS FULLY ENGAGED ALONG THE ENTIRE LENGTH. ALLOW A 3/8" GAP BETWEEN COVER SECTIONS. FIELD CUT WHERE NECESSARY USING A FINE TOOTH HACKSAW.



Customer Service
Phone: 800-969-0108
Fax: 610-916-9501

DATE: 09/12/19
DRN BY: ZS
CKD BY: JAI

SHT.# 6 OF 6
DWG# 28110-11796

F