

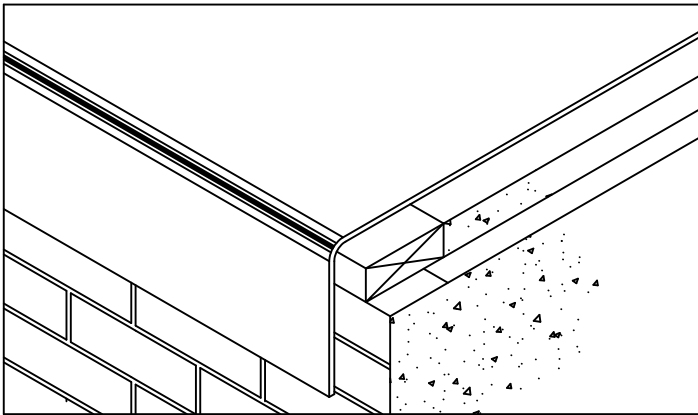

FLEXLOCK FLT ROOF EDGE

BUILT-UP OR MODIFIED VERSION

LAP JOINT VERSION INSTALLATION INSTRUCTIONS



1. Built-Up or Modified Roofing

Position base sheet of the built-up or modified roofing membrane over the roof edge covering nailers completely.

NOTE: Follow general recommendations of the roofing manufacturers application of the membrane over the edge.

CAUTION: Take extreme care to avoid spillage of the asphalt over the edge.

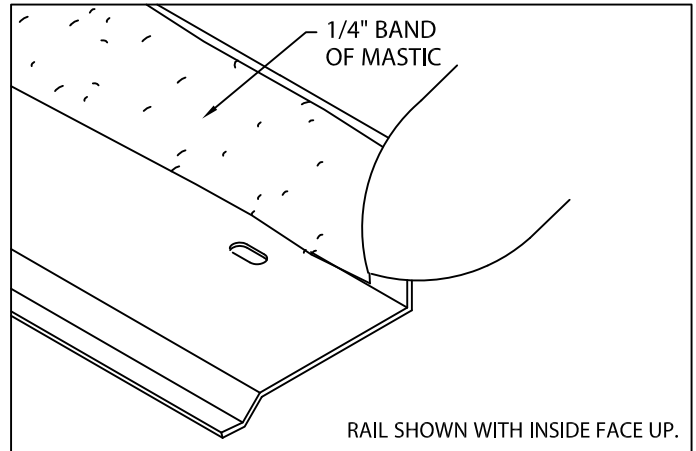

2. Miter & Scupper Base Rail (Preparation)

Lay miters and spillover scuppers on deck with outside face down. Be sure aluminum base rail is clean and free of dirt or dust. Apply a heavy 1/4" band of approved mastic/sealant to the back of the deck flange to entire length of base rail as shown. Application of sealant is required along the full length of each miter base rail.

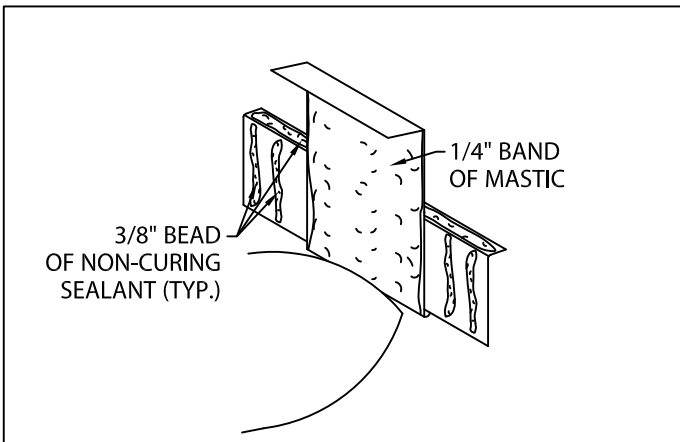

3. Base Rail Splice Plate

Apply a heavy 1/4" band of approved mastic/sealant to the bottom of the 2" wide deck flange of the rail splice as shown. Next, apply 3/8" beads of non-curing sealant to top and sides of the rail splice as shown.

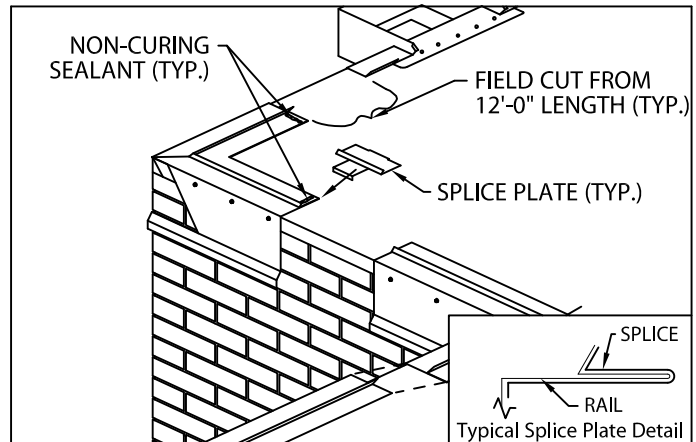

4. Base Rail Miter Installation

Apply non-curing sealant to top ends of rail as shown. Fasten rail corners, with one splice plate under each end of corner, using 2" hex head stainless steel fasteners and driver bit furnished by Flex. Next locate and install spillovers and scuppers with splice plates, sealant and 2" fasteners.



Customer Service
Phone: 800-969-0108
Fax: 610-916-9501

DATE: 03/27/17
DRN BY: JAB
CKD BY: SAK

SHT.# 1 OF 3
DWG# 28110-11375

E



FLEXLOCK FLT ROOF EDGE

BUILT-UP OR MODIFIED VERSION

LAP JOINT VERSION INSTALLATION INSTRUCTIONS

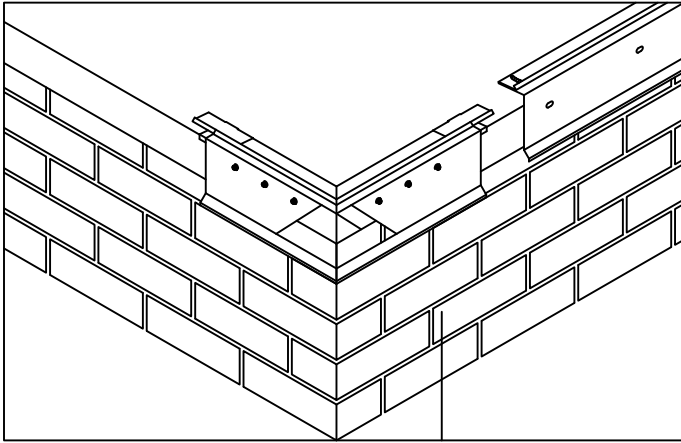

5. Base Rail Installation

Install 12'-0" sections of base rail with mastic and non-curing sealant as shown in Steps 2 & 4. Install base rail from right to left, (as seen from roof top). Leave a 3/8" gap between rail sections. Fasten base rail 12" O.C. through the slots using the 2" stainless steel fasteners provided. Field cut sections as necessary.

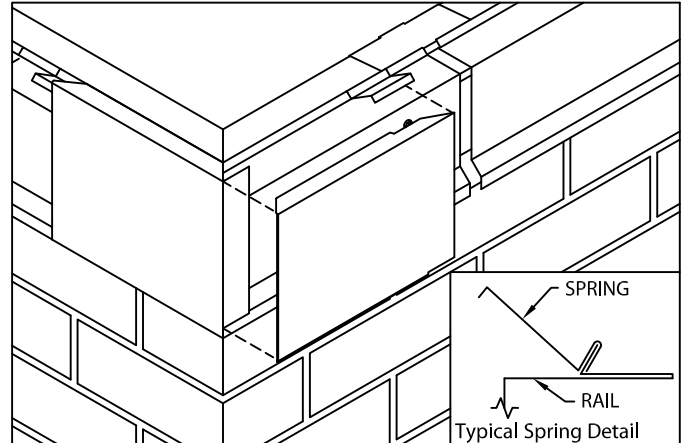

6. Fascia Miter Covers

Position (2) 6" wide stainless steel springs at each end of fascia miter cover. Install 2-piece "snap-on" fascia miter covers first by snapping on fascia corner miter with 90° (degree) tab, followed by fascia cover without the tab. Simply position the cover atop rail and with palm of hand apply slight pressure downward until engaged to base rail.

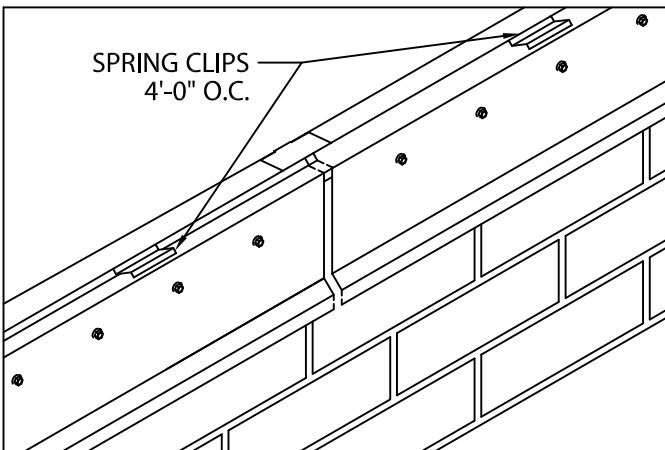

7. Spring Clips

Position 6" wide stainless steel spring clips starting at fascia cover end and every 4'-0" on the installed base rail as shown.

IMPORTANT! Be sure to remove protective plastic film prior to installing each fascia section.

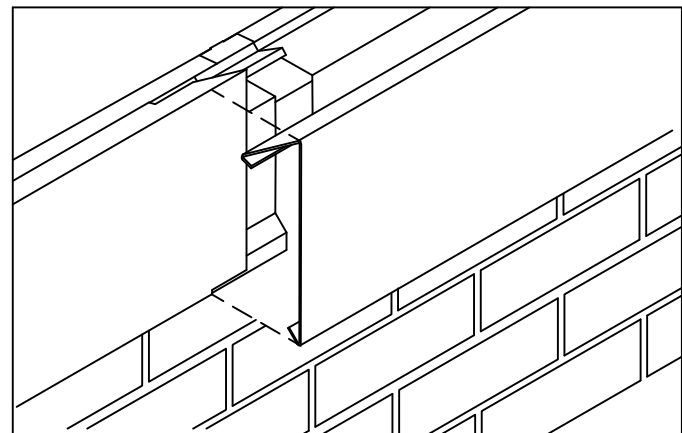

8. Fascia Covers

Position 12'-0" fascia covers on top of base rail and overlap preceding panel at a minimum of 1" at notches provided. Fascia covers shall be installed from right to left as seen from rooftop. With fascia covers in correct position atop base rail, simply snap each section onto base rail by applying downward pressure with palm of the hand until the fascia cover is fully engaged along the entire length. Continue to install fascia covers, field cutting where necessary using fine tooth hacksaw.



Customer Service
Phone: 800-969-0108
Fax: 610-916-9501

DATE: 03/27/17

DRN BY: JAB

CKD BY: SAK

SHT.# 2 OF 3

DWG# 28110-11375

E



FLEXLOCK FLT ROOF EDGE

BUILT-UP OR MODIFIED VERSION

LAP JOINT VERSION INSTALLATION INSTRUCTIONS

TYPICAL INSTALLATION

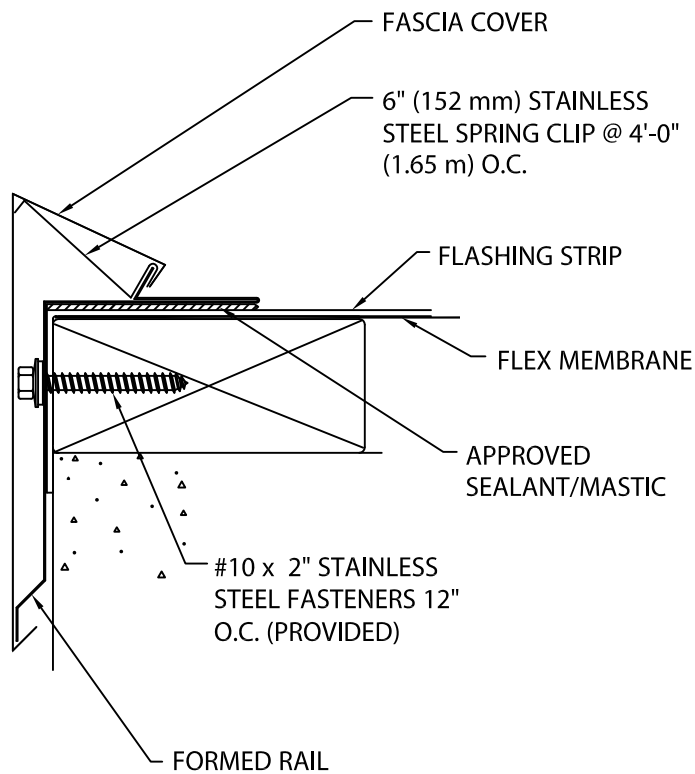

U.S. Patent # 5,927,023



Customer Service
Phone: 800-969-0108
Fax: 610-916-9501

DATE: 03/27/17

DRN BY: JAB

CKD BY: SAK

SHT.# 3 OF 3

DWG# 28110-11375

E