

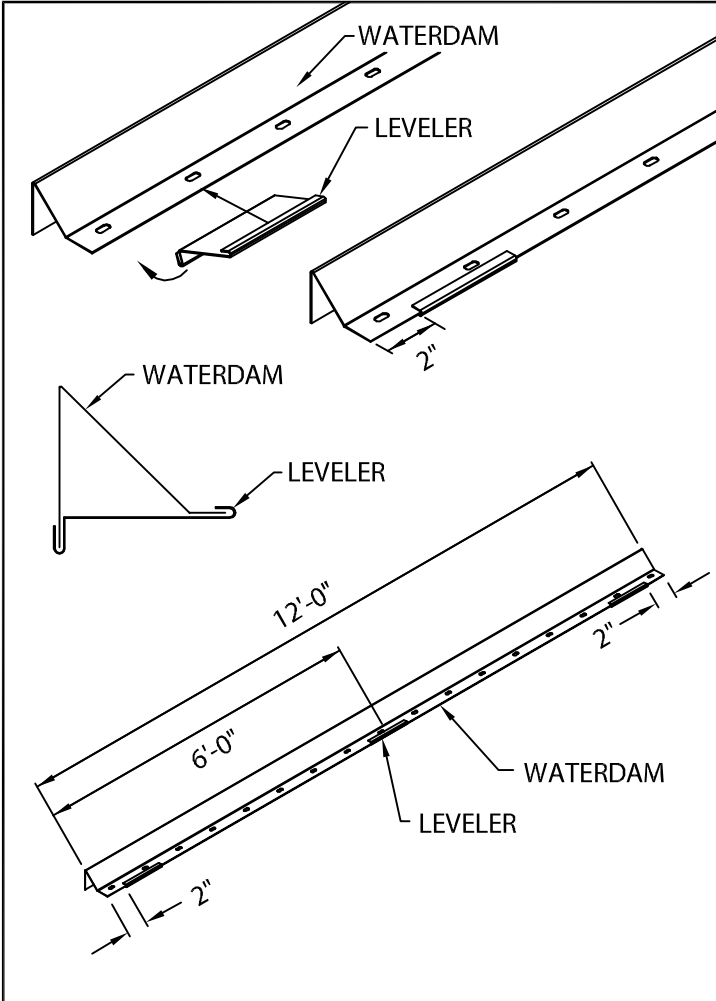

FIBERTITE EXTENDED CANTED FASCIA

GALVANIZED WATERDAM VERSION

INSTALLATION INSTRUCTIONS



1. WATERDAM & LEVELER

POSITION LEVELER 2" FROM END OF WATERDAM, HOOKING ONTO WATERDAM AND ROTATING INTO PLACE AS SHOWN. DO THE SAME AT THE OTHER END OF 12'-0" LENGTH OF WATERDAM. ALSO PLACE A LEVELER IN CENTER OF 12'-0" LENGTH (3 LEVELERS PER 12'-0" LONG WATERDAM). DO THE SAME FOR MITERS, 2" FROM END OF WATERDAM (2 LEVELERS PER MITER).

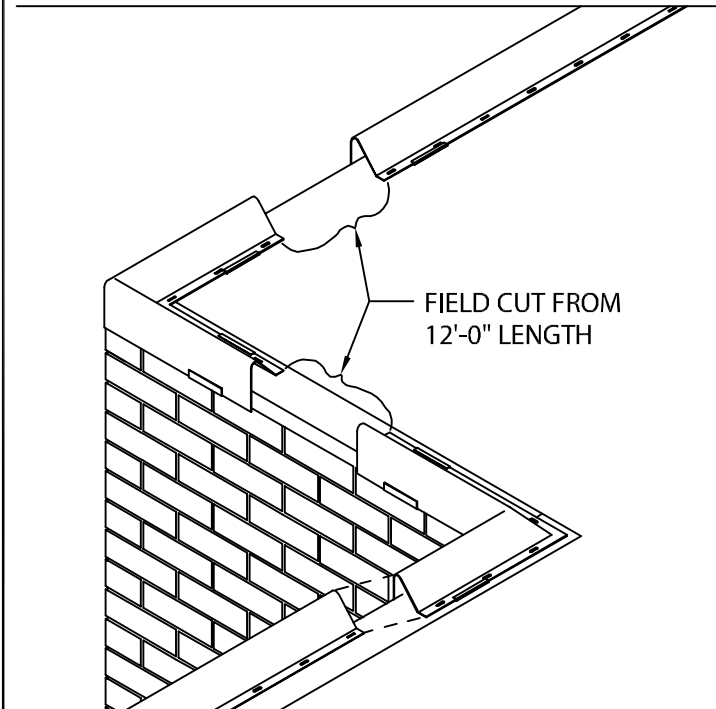

2. WATERDAM

LOCATE AND INSTALL WATERDAM MITERS, NAILING THROUGH PRE-SLOTTED FASTENING HOLES ON TOP OF NAILER(S). DETERMINE AND IDENTIFY LOCATIONS OF SCUPPERS AT THIS TIME. LEAVE GAP OF 14 1/2" FOR SCUPPER LOCATIONS. NEXT, INSTALL 12'-0" SECTIONS OF WATERDAM FROM RIGHT TO LEFT (AS SEEN FROM ROOF TOP) BY NAILING THROUGH PRE-PUNCHED HOLES PROVIDED ON TOP OF NAILER(S). BE SURE TO OVERLAP WATERDAM 1".

NOTE: PROVIDED WATERDAM FASTENER: 1 1/4" RING SHANK GALVANIZED ROOFING NAILS.

CAUTION : INSTALLERS SHALL WEAR PROTECTIVE EYEWEAR TO PREVENT SERIOUS INJURY.



Phone: 800-927-8578
ext. 1235
fax: 330-263-6950

DATE: 03/20/17
DRN BY: JJC
CKD BY: SAK

SHT.# 1 OF 5
DWG# 23110-2436

J



FIBERTITE EXTENDED CANTED FASCIA

GALVANIZED WATERDAM VERSION

INSTALLATION INSTRUCTIONS

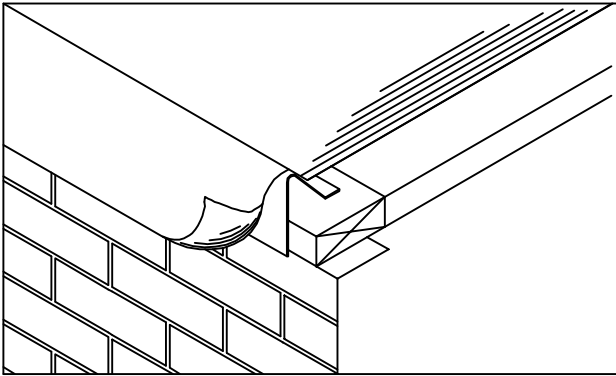

3. ROOFING MEMBRANE

FOLLOW GENERAL RECOMMENDATIONS OF THE ROOF MEMBRANE MANUFACTURERS APPLICATION OF MATERIALS OVER THE ROOF EDGE.

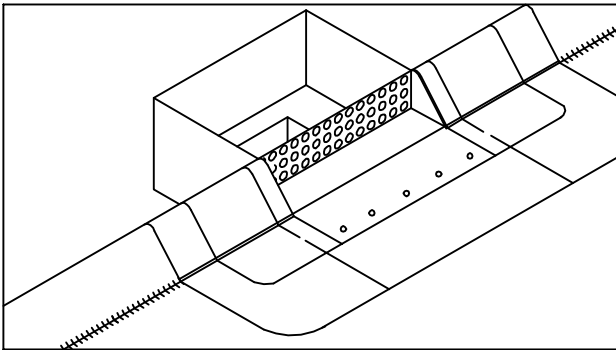

4. SCUPPERS

INSTALL SPILLOUT OR DOWNSPOUT SCUPPERS (IF APPLICABLE) AT PREDETERMINED LOCATIONS.

NOTE : ROOF MEMBRANE IS INSTALLED UNDER SCUPPER. SCUPPER FLANGE IS SET IN A CONTINUOUS BEAD OF NON-CURING SEALANT.

NOTE : FOLLOW GENERAL RECOMMENDATIONS OF THE ROOF MEMBRANE MANUFACTURERS APPLICATION ON STRIPPING IN THE SCUPPER.



FIBERTITE EXTENDED CANTED FASCIA

GALVANIZED WATERDAM VERSION

INSTALLATION INSTRUCTIONS

IMPORTANT!
CLEAT MUST
BE HOOKED
INTO MITER
BAR BEFORE
INSTALLING!

#10 x 2" STAINLESS STL. SCREW
1/4" x 1 1/4"
WOOD/MASONRY SCREW

MITER CLEAT
FLUSH TO OUTSIDE
EDGE OF MITER BAR

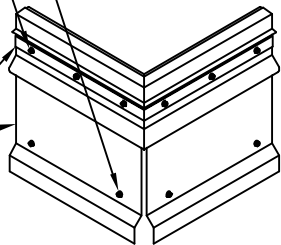

5. MITER BAR & MITER CLEAT INSTALLATION

HOOK MITER CLEAT PIECES TO MITER BAR. FLUSH ENDS OF MITER CLEAT PIECE AND MITER BAR. INSTALL MITER ASSEMBLY WITH ONE ANCHOR BAR SPLICE PLATE UNDER EACH END OF MITER BAR. FASTEN THE MITER BAR USING 2" HEX HEAD STAINLESS STEEL FASTENERS. FASTENERS AND DRIVE BITS PROVIDED. NEXT LOCATE AND INSTALL THE SPILLOUTS AND SCUPPERS WITH FASTENERS AND SPLICE PLATES.

6. ANCHOR BAR & CLEAT INSTALLATION

HOOK ANCHOR CLEAT TO ANCHOR BAR AS SHOWN IN STEP 4. POSITION 12'-0" ANCHOR BAR/CLEAT SECTIONS OVERLAPPING BAR SPLICE PLATE. ALLOW 3/8" SPACE BETWEEN ANCHOR BARS. INSTALL BAR SPLICE PLATE AT OTHER END OF BAR/CLEAT SECTION. FASTEN ANCHOR BAR 12" O.C. THROUGH THE SLOTTED HOLES USING PROVIDED 2" FASTENERS. FASTEN ANCHOR CLEAT 24" O.C. THROUGH SLOTTED HOLES USING PROVIDED 1 1/4" FASTENERS. FIELD CUT SECTIONS AS IS NECESSARY.

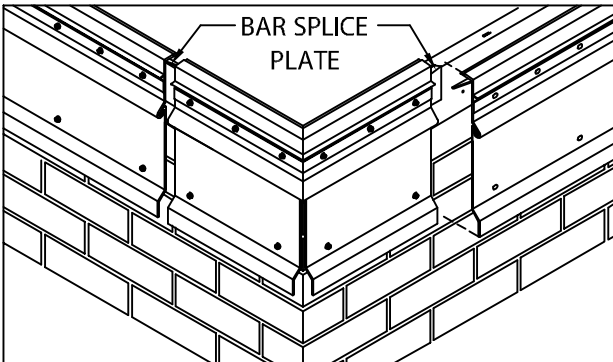

7. FASCIA MITERS COVERS

INSTALL MITER COVERS FIRST. INSERT ONE SPLICE PLATE UNDER EACH END OF THE TWO PIECE MITER COVER. ENGAGE COVER WITH 90° TAB ONTO BOTTOM OF ANCHOR BAR AND ROTATE MITER COVER UP AND OVER ANCHOR BAR MITER UNTIL ENGAGED ALONG ENTIRE LENGTH OF THE ANCHOR BAR. REPEAT STEPS TO INSTALL MITER COVER WITHOUT THE 90° TAB.

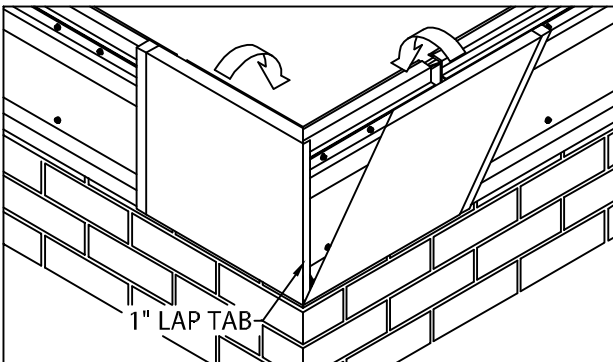

1" LAP TAB

8. FASCIA COVERS

INSTALL 12'-0" FASCIA COVER SECTIONS. ALLOW A 3/8" GAP BETWEEN FASCIA COVER SECTIONS. INSERT ONE SPLICE PLATE UNDER FAR END OF EACH FASCIA COVER SECTION. INSTALL COVER BY HOOKING LOWER EDGE OF COVER ONTO ANCHOR CLEAT AND ROTATING UP AND OVER ANCHOR BAR UNTIL ENGAGED ALONG ENTIRE LENGTH OF COVER SECTION. CONTINUE TO INSTALL COVER SECTIONS IN THIS MANNER, FIELD CUTTING WHERE NECESSARY USING A FINE TOOTH HACKSAW.

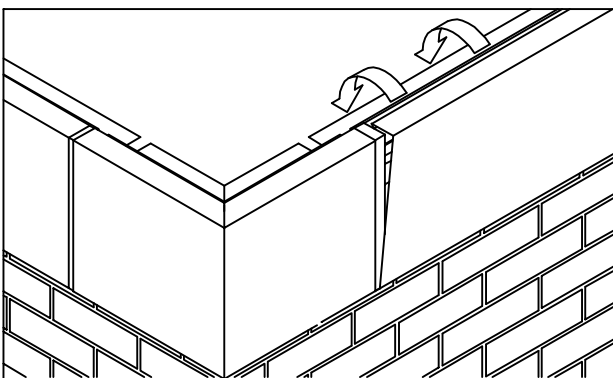

IMPORTANT !

BE SURE TO REMOVE PROTECTIVE FILM
PRIOR TO INSTALLING EACH FASCIA SECTION.



Phone: 800-927-8578
ext. 1235
fax: 330-263-6950

DATE: 03/20/17

DRN BY: JJC

CKD BY: SAK

SHT.# 3 OF 5

DWG# 23110-2436

J



FIBERTITE EXTENDED CANTED FASCIA

GALVANIZED WATERDAM VERSION

INSTALLATION INSTRUCTIONS

TYPICAL INSTALLATION

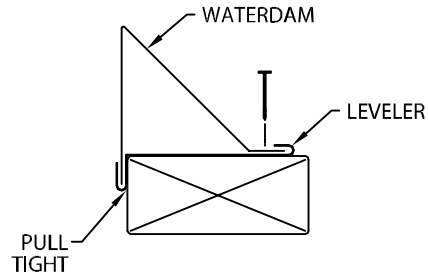
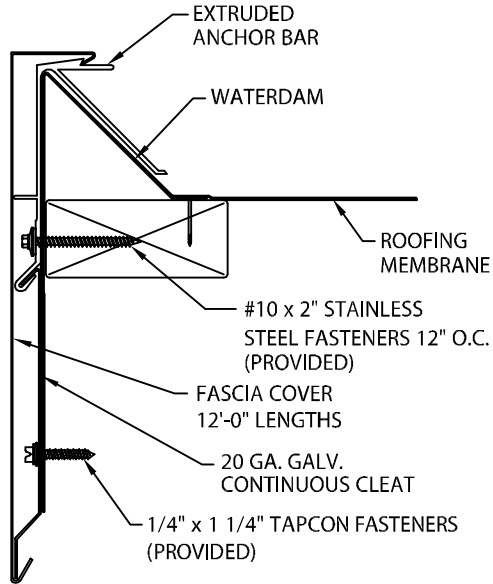

WATERDAM MUST BE PULLED TIGHT TO THE OUTSIDE FACE OF THE BUILDING BEFORE NAILING THE ROOF FLANGE.

U.S. Patent # 7,451,572



Phone: 800-927-8578
ext. 1235
fax: 330-263-6950

DATE: 03/20/17
DRN BY: JJC
CKD BY: SAK

SHT.# 4 OF 5
DWG# 23110-2436

J



FIBERTITE EXTENDED CANTED FASCIA

GALVANIZED WATERDAM VERSION

INSTALLATION INSTRUCTIONS

COMPONENT LIST

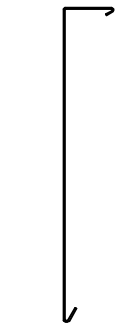

FASCIA COVER
12'-0" LENGTHS

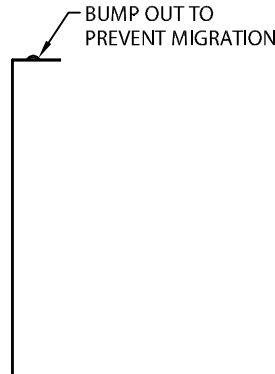

COVER SPLICE PLATE
3 1/2" WIDE

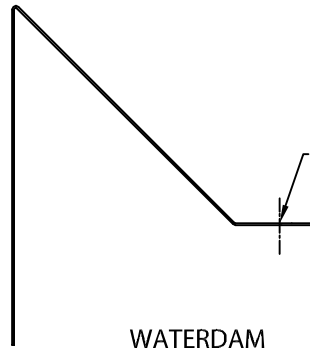

WATERDAM
12'-0" LENGTHS

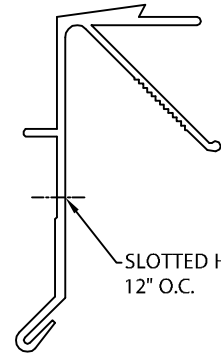

EXTRUDED ANCHOR BAR
12'-0" LENGTHS

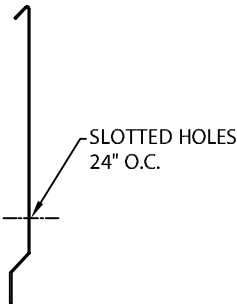

CONTINUOUS ANCHOR CLEAT
12'-0" LENGTHS



LEVELER
4" WIDE



#10 x 2" STAINLESS STEEL
SCREWS W/WASHER FOR
INSTALLING ANCHOR BAR



1/4" x 1 1/4" TAPCON SCREWS
W/WASHER FOR INSTALLING
ANCHOR CLEAT

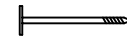

1/4" RING SHANK ROOFING
NAIL FOR INSTALLING
WATERDAM

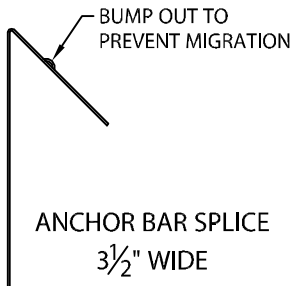

ANCHOR BAR SPLICE
3 1/2" WIDE

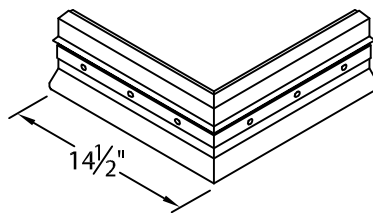

OUTSIDE ANCHOR BAR
MITER

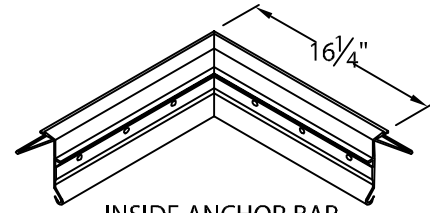

INSIDE ANCHOR BAR
MITER

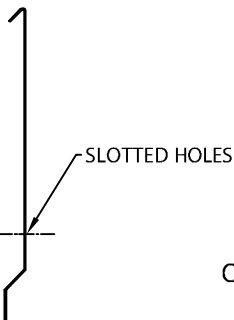

ANCHOR CLEAT FOR MITERS
(2) 14" LONG PCS. PER MITER

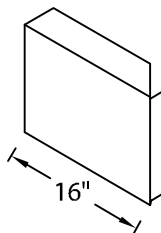

OUTSIDE MITER COVER
WITH TAB

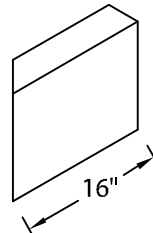

OUTSIDE MITER COVER
WITHOUT TAB

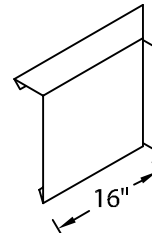

INSIDE MITER COVER
WITH TAB

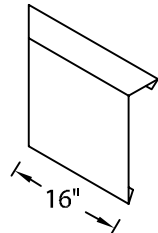

INSIDE MITER COVER
WITHOUT TAB



Phone: 800-927-8578
ext. 1235
fax: 330-263-6950

DATE: 03/20/17
DRN BY: JJC
CKD BY: SAK

SHT.# 5 OF 5

DWG# 23110-2436

J