

DOW DRIP EDGE

90° VERSION WITH CONTINUOUS CLEAT

ANSI/SPRI ES-1 TESTED

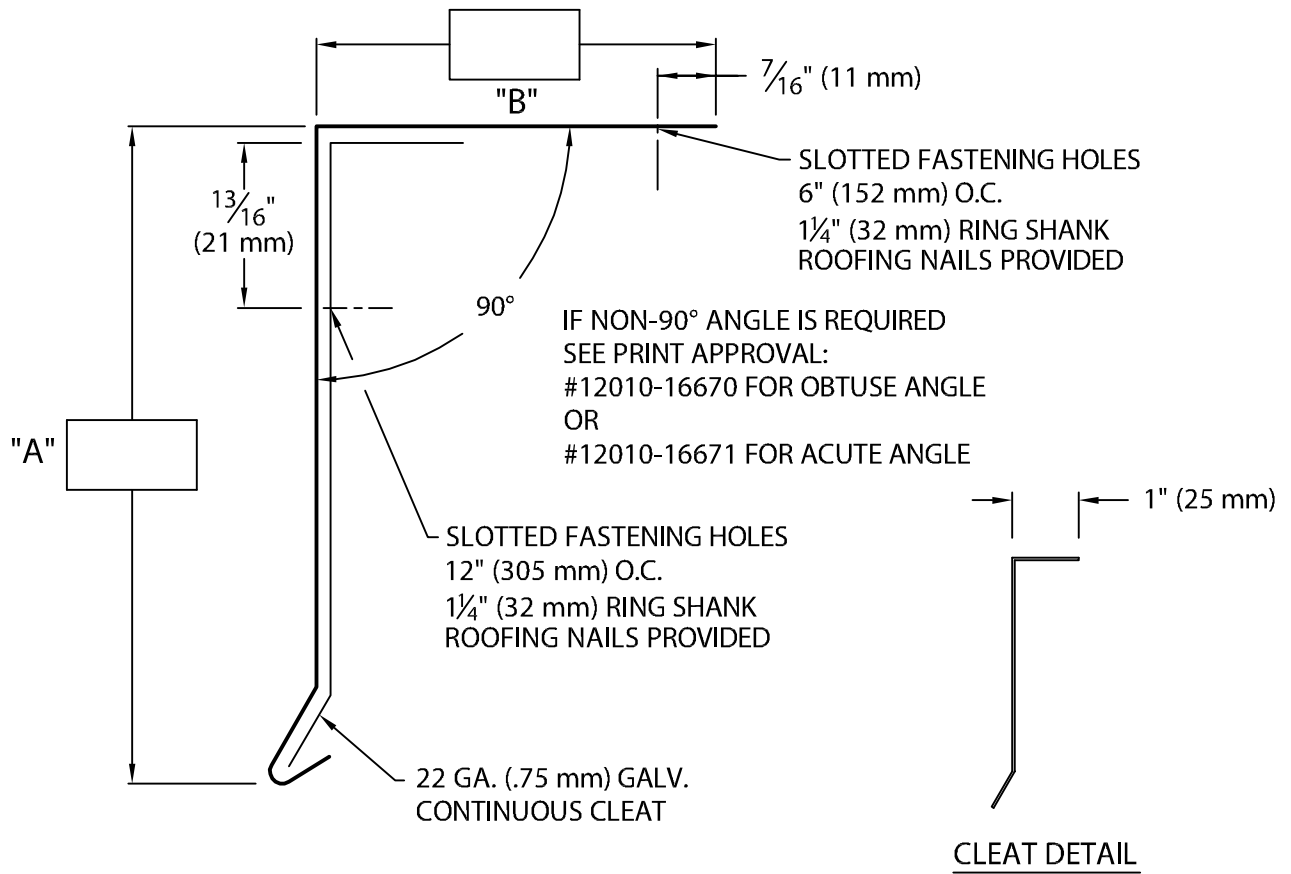

NOTES:

- Includes 6" (152 mm) wide concealed splice plates.
- Concealed splice plate must be field caulked to prevent water entry.
- Unless otherwise noted, fabrication of miters and accessories are furnished standard utilizing a non-penetrating quicklock joint, then factory sealed watertight.

Fabrication will proceed only after receipt of signed print approval.

Print Approval:

Architect and/or contractor shall verify all dimensions, sizes and quantities. All products to be installed in strict accordance with Dow Roofing Systems' printed instructions.

Approved by: _____

Date: _____

-- Welded Miters and Accessories

Check one Required (surcharge) Not applicable

MATERIAL:

____ 24 Ga. (.65 mm) Galv.
 ____ .040" (1.01 mm) Alum. Color: _____
 ____ .050" (1.27 mm) Alum.
 ____ .063" (1.60 mm) Alum. Finish: _____
 ____ OTHER _____

QUANTITIES:

_____ Lineal Feet (12'-0" (3.65 m) Lengths)
 _____ Outside Miters @ (____°)
 _____ Inside Miters @ (____°)

PROJECT:

ARCHITECT:

ROOFING CONTRACTOR:

REPRESENTATIVE/DISTRIBUTOR:

Corporate Offices
 Dow Roofing Systems
 Nine Sullivan Road
 Holyoke, MA 01040
 P: 800-621-ROOF



ROOFING SYSTEMS

DATE: 11/13/12

DRN BY: JJC

CKD BY: SAK

SHT.# ____ OF ____

DWG# 12010-3010

E