

STEP-UP COPING MITERS

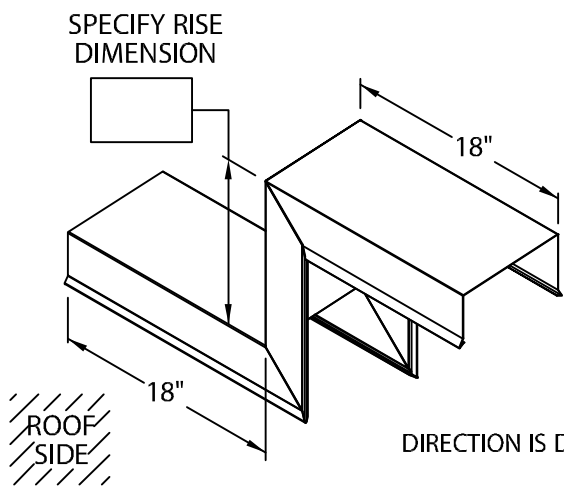

LEFT HAND STEP-UP MITER

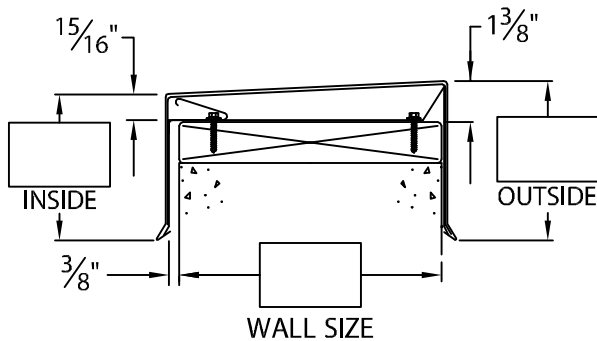
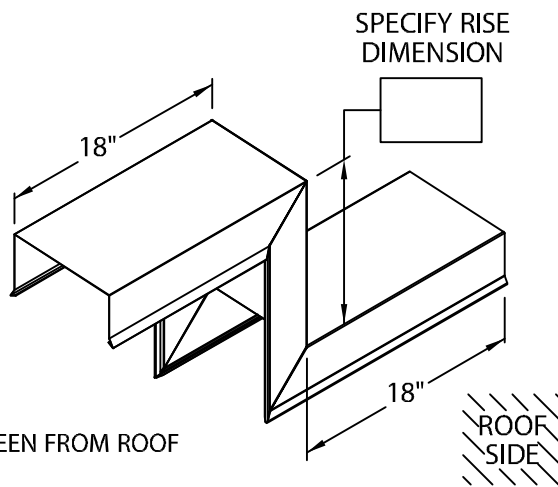

RIGHT HAND STEP-UP MITER

DIRECTION IS DETERMINED AS SEEN FROM ROOF

FOR CUSTOM LEG LENGTHS MODIFY DRAWINGS ABOVE

NOTES:

- ① FABRICATION OF MITERS AND ACCESSORIES ARE FURNISHED STANDARD UTILIZING A NON-PENETRATING QUICKLOCK JOINT, THEN FACTORY SEALED WATERTIGHT.

MATERIAL:

- ___ 24 GA. GALVANIZED STEEL
- ___ 22 GA. GALVANIZED STEEL
- ___ .040" ALUMINUM

COLOR: _____

FINISH: _____

QUANTITIES: ①

___ RIGHT HAND STEP-UP MITER

___ LEFT HAND STEP-UP MITER

AUTHORIZED SIGNATURE:

APPROVED BY: _____

DATE: _____

PROJECT:

ARCHITECT:

ROOFING CONTRACTOR:

REPRESENTATIVE/DISTRIBUTOR:



PHONE: 800-794-2701

DATE: 03/17/17

DRN BY: JJC

CKD BY: SAK

SHT.# ___ OF ___

DWG# 47011-21267

B