



SEAL-TITE GOLD INDUSTRIAL GUTTER

IGG-1, IGG-2, IGG-3 OR IGG-B VERSION WITH WIND STRAPS

INSTALLATION INSTRUCTIONS

NOTE: EITHER TERMINATION BAR, GRAVEL STOP OR DRIP EDGE MUST BE USED TO RECEIVE <FM> APPROVAL.

TYPICAL MEMBRANE OPTIONS

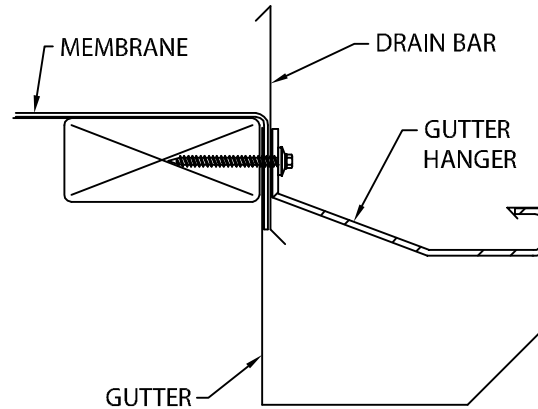
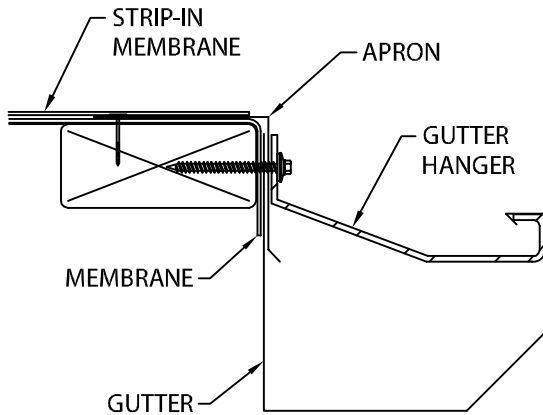

STEP 1. MEMBRANE INSTALLATION

REVIEW CAREFULLY AND FOLLOW PRIMARY ROOF MATERIAL MANUFACTURER'S RECOMMENDATIONS, AND ARCHITECT'S DETAILS FOR INSTALLING ROOF MEMBRANES IN CONJUNCTION WITH THIS GUTTER SYSTEM.

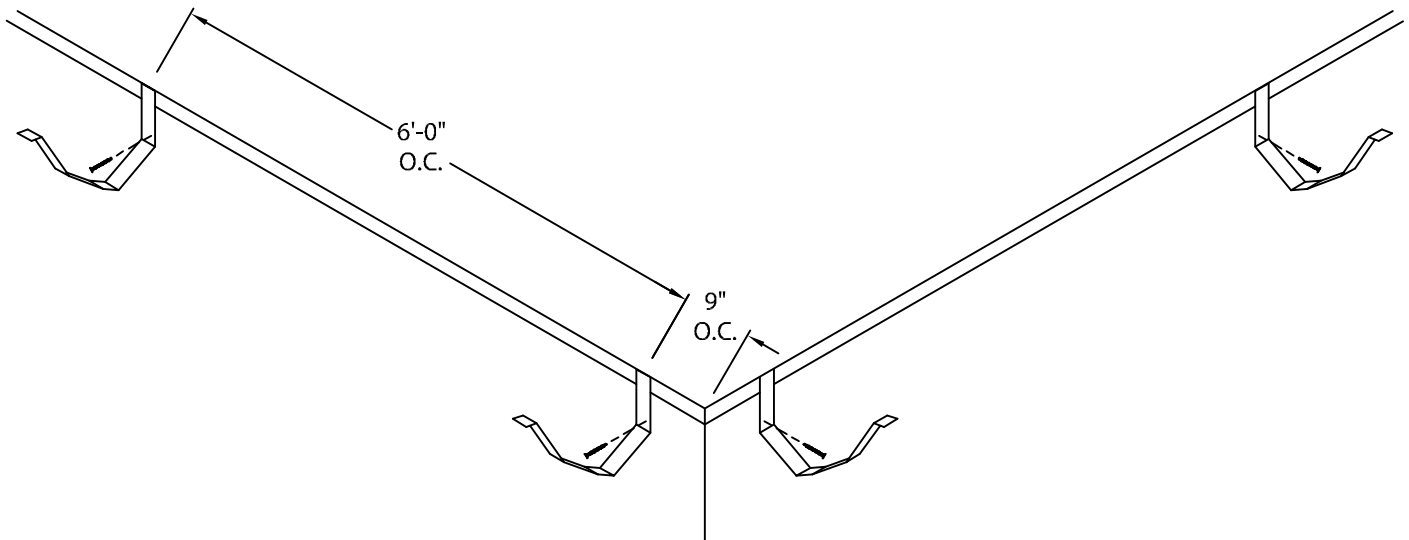

STEP 2. WIND STRAPS

START BY FASTENING WIND STRAPS TO WALL 9" O.C. FROM CORNER WITH PROVIDED 14 x 2" METAL/WOOD/MASONRY SCREWS. CONTINUE INSTALLING WIND STRAPS AT 6'-0" O.C.



Phone: 800-558-2162
Fax: 800-373-9156
www.metalera.com

DATE: 05/02/17
DRN BY: JJC
CKD BY: SAK

SHT.# 1 OF 5
DWG# 11112-26122

B



SEAL-TITE GOLD INDUSTRIAL GUTTER

IGG-1, IGG-2, IGG-3 OR IGG-B VERSION WITH WIND STRAPS

INSTALLATION INSTRUCTIONS

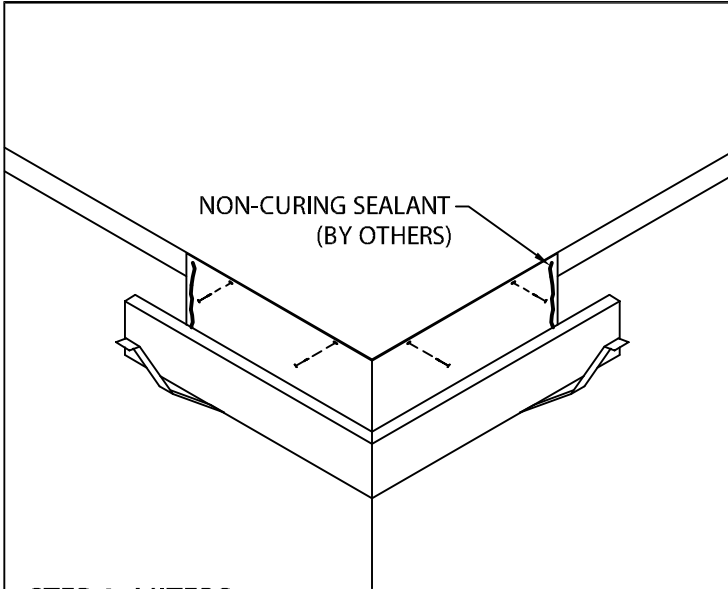

STEP 3. MITERS

INSTALL MITERS AT LOCATIONS SHOWN ON PLANS. WRAP WIND STRAPS AROUND MITERS. FASTEN MITER TO NAILER THROUGH PRE-SLOTTED HOLES USING PROVIDED $1\frac{1}{4}$ " GALVANIZED ROOFING NAILS. APPLY A HEAVY BEAD OF NON-CURING SEALANT TO THE INSIDE OF EACH MITER END AS SHOWN.

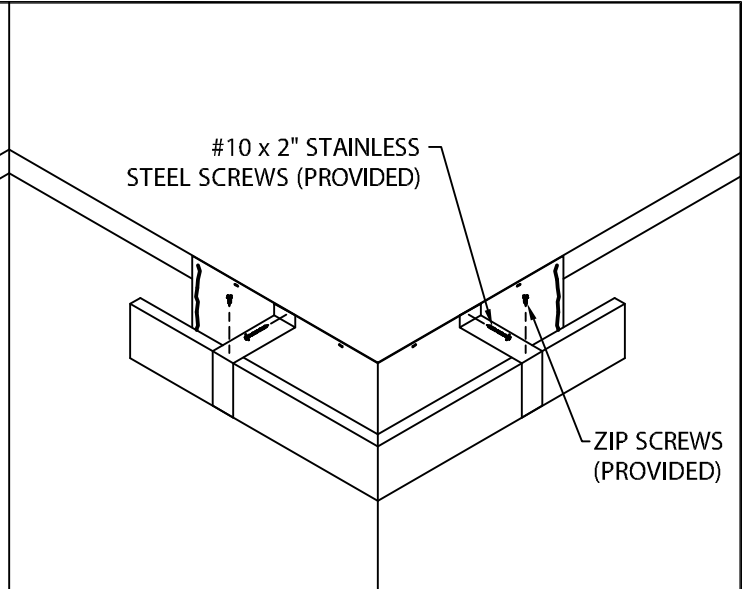

STEP 4. MITER WIND STRAPS

WRAP WIND STRAPS AROUND TOP OF GUTTER AND FASTEN TO GUTTER WITH PROVIDED #10 x 2" STAINLESS STEEL FASTENERS AND ZIP SCREWS.

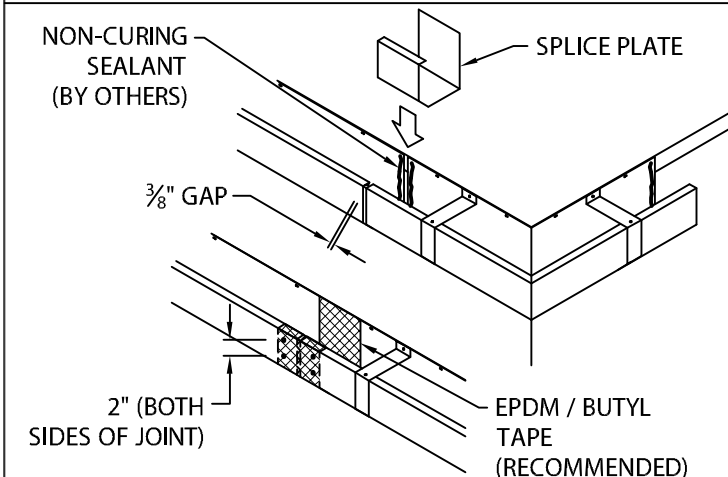

STEP 5. GUTTER

INSTALL GUTTER SECTIONS FROM RIGHT TO LEFT AS SEEN FROM ROOF. APPLY A HEAVY BEAD OF NON-CURING SEALANT TO INSIDE LENGTH OF GUTTER. LEAVE A $\frac{3}{8}$ " GAP AT SPLICE JOINT. PLACE 6" WIDE SPLICE PLATE AT JOINT. RIVET SECTIONS WITH PROVIDED $\frac{1}{8}$ " STAINLESS STEEL POP RIVETS AT SPLICE JOINT 2" O.C. AS SHOWN. NAIL GUTTER TO NAILER AT 12" O.C. USING PROVIDED $1\frac{1}{4}$ " RING SHANK ROOFING NAILS. METAL-ERA RECOMMENDS THE APPLICATION OF EPDM / BUTYL PRESSURE SENSITIVE TAPE CENTERED OVER THE SPLICE PLATE AND LAPPING GUTTER SECTIONS A MINIMUM OF 1".

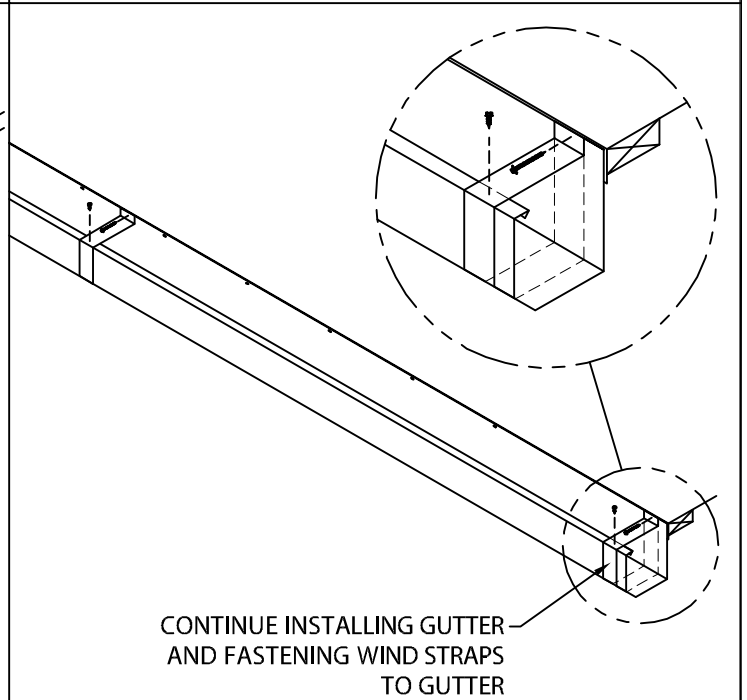

STEP 6. WIND STRAPS

CONTINUE INSTALLING GUTTER AND FASTENING WIND STRAPS TO GUTTER.



Phone: 800-558-2162
Fax: 800-373-9156
www.metalera.com

DATE: 05/02/17
DRN BY: JJC
CKD BY: SAK

SHT.# 2 OF 5
DWG# 11112-26122

B



SEAL-TITE GOLD INDUSTRIAL GUTTER

IGG-1, IGG-2, IGG-3 OR IGG-B VERSION WITH WIND STRAPS

INSTALLATION INSTRUCTIONS

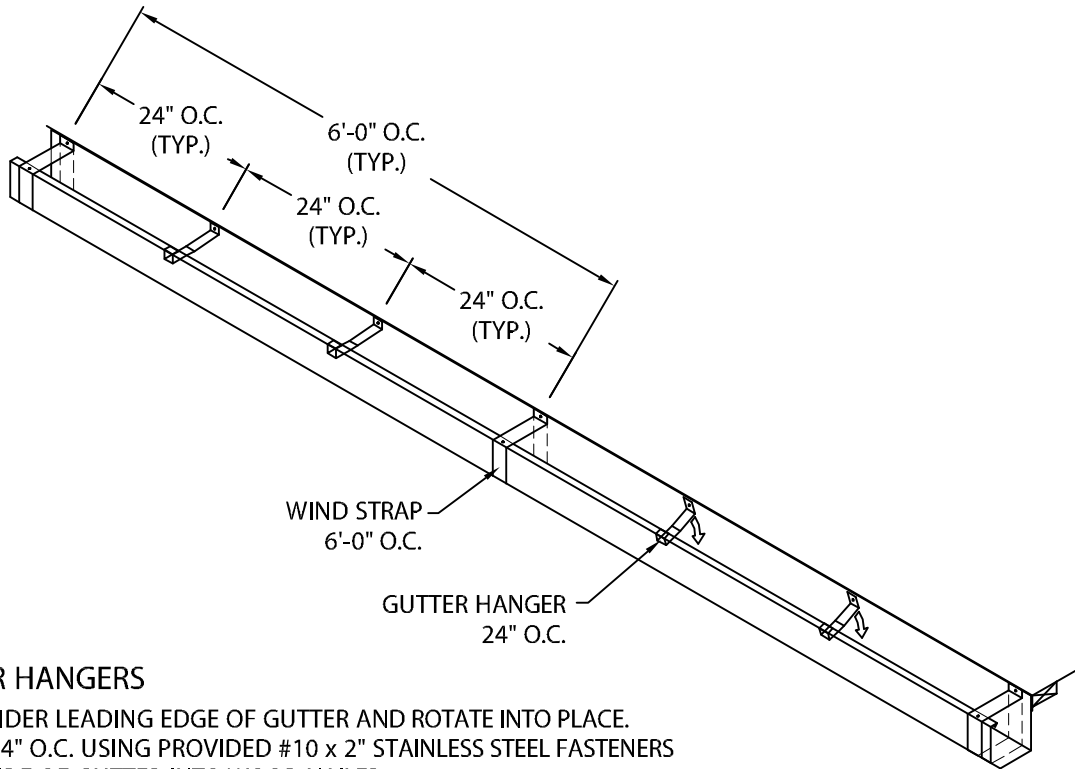

STEP 7. GUTTER HANGERS

HOOK HANGER UNDER LEADING EDGE OF GUTTER AND ROTATE INTO PLACE. FASTEN HANGER 24" O.C. USING PROVIDED #10 x 2" STAINLESS STEEL FASTENERS THROUGH BACK SIDE OF GUTTER INTO WOOD NAILER.

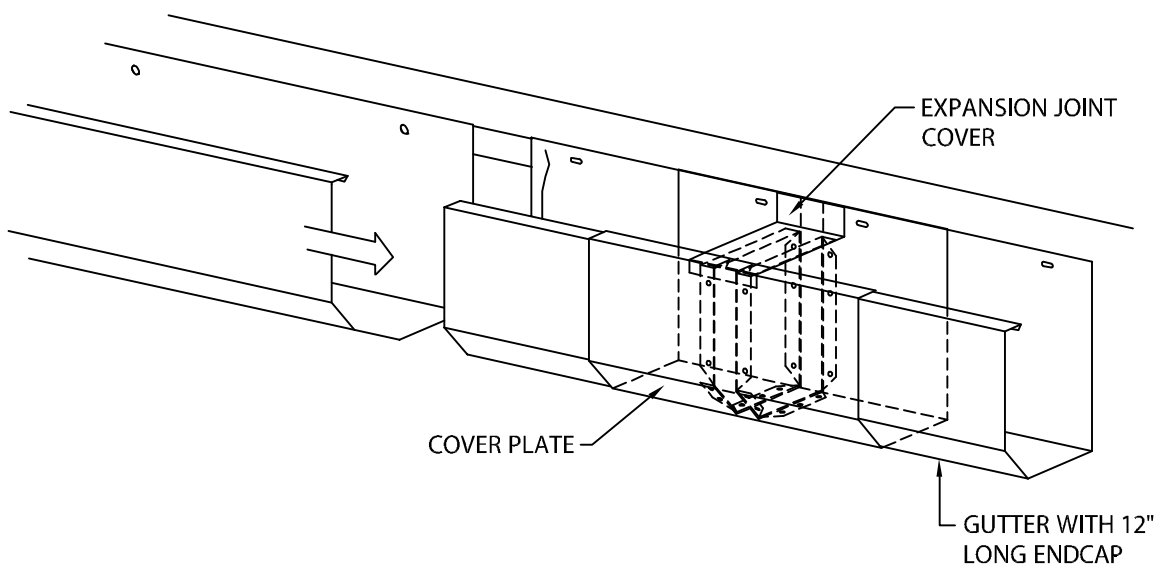

STEP 8. EXPANSION JOINT INSTALLATION (WHERE NECESSARY)

INSTALL EXPANSION JOINTS IN LOCATIONS AS SPECIFIED ON ROOF PLANS OR AT A MAXIMUM OF 48'-0". NAIL INTO PLACE AS PER STEP 5.



Phone: 800-558-2162
Fax: 800-373-9156
www.metalera.com

DATE: 05/02/17
DRN BY: JJC
CKD BY: SAK

SHT.# 3 OF 5
DWG# 11112-26122

B



SEAL-TITE GOLD INDUSTRIAL GUTTER

IGG-1, IGG-2, IGG-3 OR IGG-B VERSION WITH WIND STRAPS

INSTALLATION INSTRUCTIONS

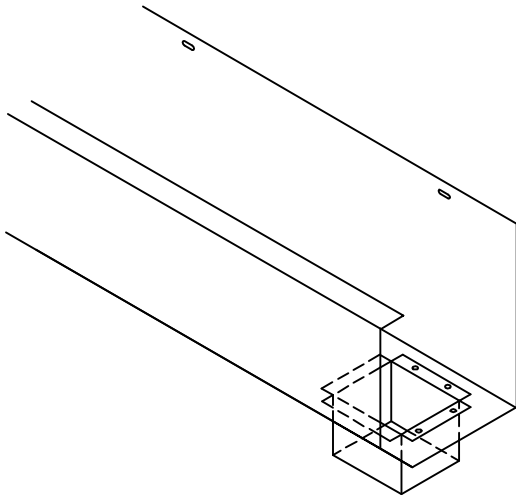

STEP 9. OUTLET INSTALLATION

DETERMINE OUTLET LOCATIONS AND FIELD CUT HOLE IN A NEAT WORKMANLIKE MANNER. INSERT ALUMINUM OUTLET, FASTEN WITH PROVIDED $\frac{1}{8}$ " STAINLESS STEEL POP RIVETS, TWO RIVETS IN EACH FLANGE AND SEAL WITH NON-CURING SEALANT.

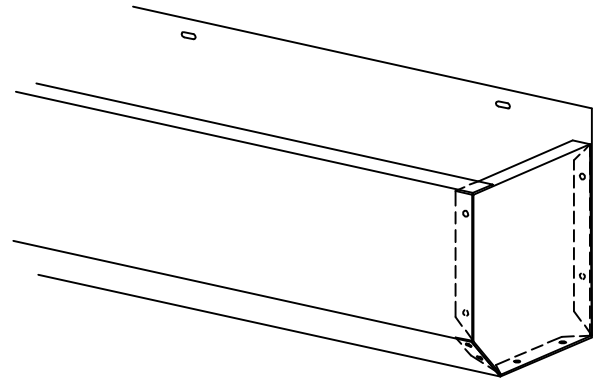

STEP 10. END CAP INSTALLATION

INSTALL ENDCAPS AT ALL TERMINATIONS. FIELD RIVET WITH PROVIDED $\frac{1}{8}$ " STAINLESS STEEL POP RIVETS AT 2" O.C. AND SEAL WITH NON-CURING SEALANT.



Phone: 800-558-2162
Fax: 800-373-9156
www.metalera.com

DATE: 05/02/17
DRN BY: JJC
CKD BY: SAK

SHT.# 4 OF 5
DWG# 11112-26122

B



SEAL-TITE GOLD INDUSTRIAL GUTTER

IGG-1, IGG-2, IGG-3 OR IGG-B VERSION WITH WIND STRAPS

INSTALLATION INSTRUCTIONS

1 CUT A 12'-0" SECTION OF THE GUTTER INTO (2) 6'-0" PIECES. (THE EXPANSION JOINT IS DESIGNED TO FIT BETWEEN THE (2) 6'-0" SECTIONS).

2 SLIDE GUTTER SECTION OVER THE EXPANSION PLATE UNTIL LEAD EDGE OF GUTTER MEETS NEOPRENE INSERT

APPLY A HEAVY BEAD OF NON-CURING SEALANT TO THE INSIDE OF THE GUTTER SECTION.

NEOPRENE (0.15 THK.) CENTER SECTION FACTORY BONDED TO .048" ALUMINUM

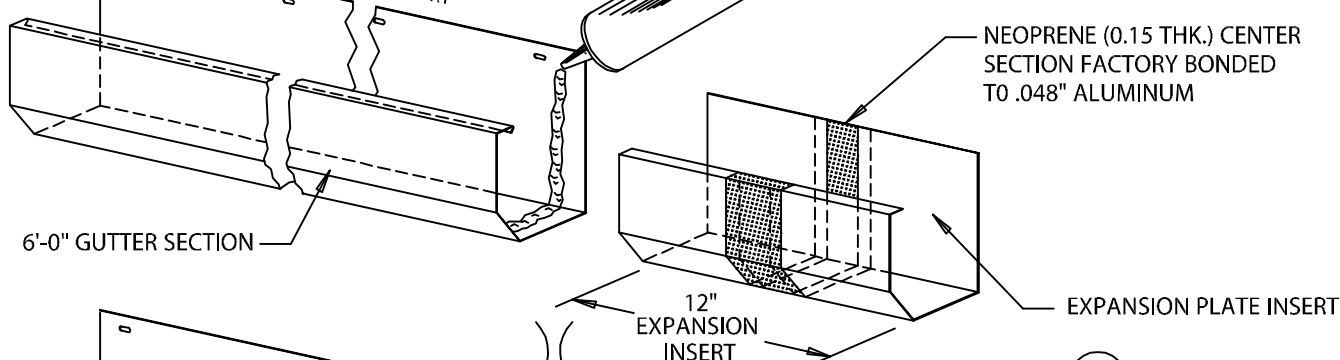

6'-0" GUTTER SECTION

12" EXPANSION INSERT

EXPANSION PLATE INSERT

4

SLIDE COVER PLATE OVER THE EXPANSION PLATE AND GUTTER SECTION PAST THE JOINT AND INSTALL SECOND GUTTER SECTION

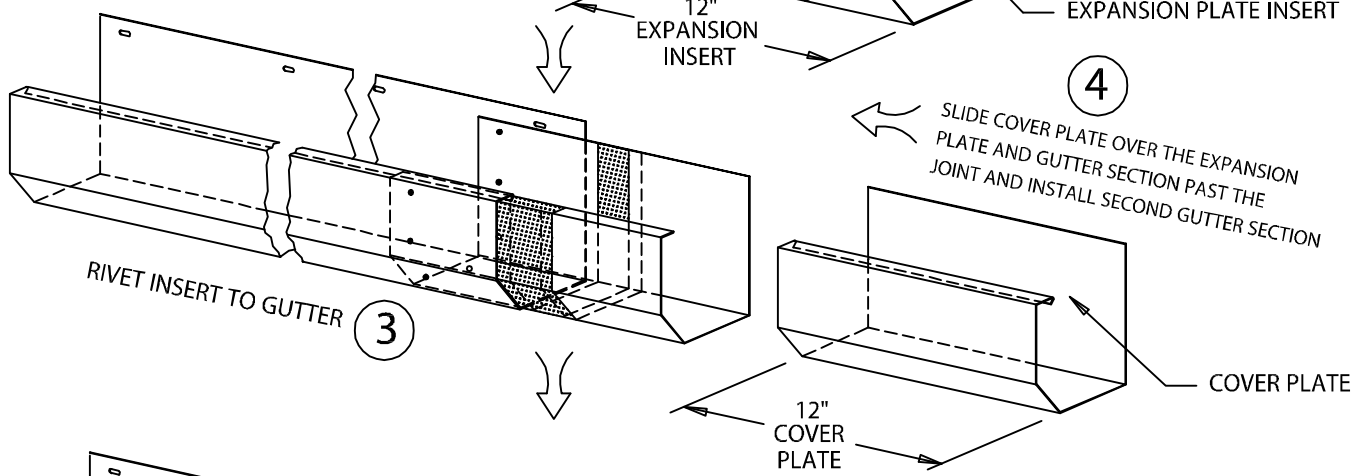

RIVET INSERT TO GUTTER

3

12" COVER PLATE

COVER PLATE

5

APPLY A HEAVY BEAD OF NON-CURING SEALANT TO THE INSIDE OF THE GUTTER SECTION.

SLIDE SECOND GUTTER SECTION OVER THE EXPANSION PLATE UNTIL THE LEAD EDGE OF GUTTER MEETS NEOPRENE INSERT AND RIVET.

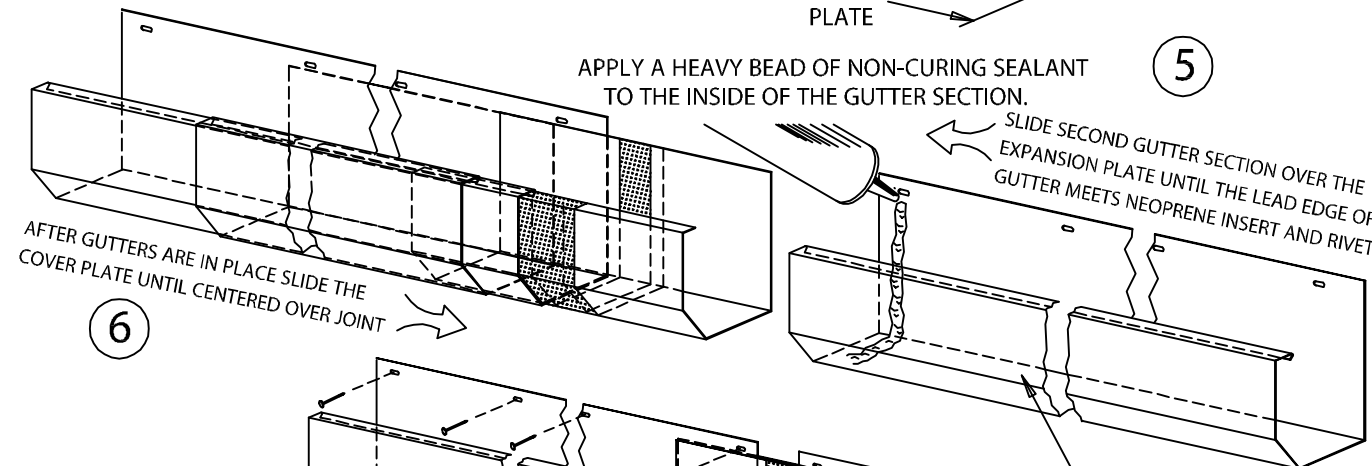

AFTER GUTTERS ARE IN PLACE SLIDE THE COVER PLATE UNTIL CENTERED OVER JOINT

6

7 COMPLETION

NOTE :

THE COVER PLATE MAY BE POP RIVETED TO THE EXPANSION PLATE AND GUTTER. BUT ONLY ON ONE SIDE TO PERMIT EXPANSION.



Phone: 800-558-2162
Fax: 800-373-9156
www.metalera.com

DATE: 05/02/17
DRN BY: JJC
CKD BY: SAK

SHT.# 5 OF 5
DWG# 11112-26122

B