

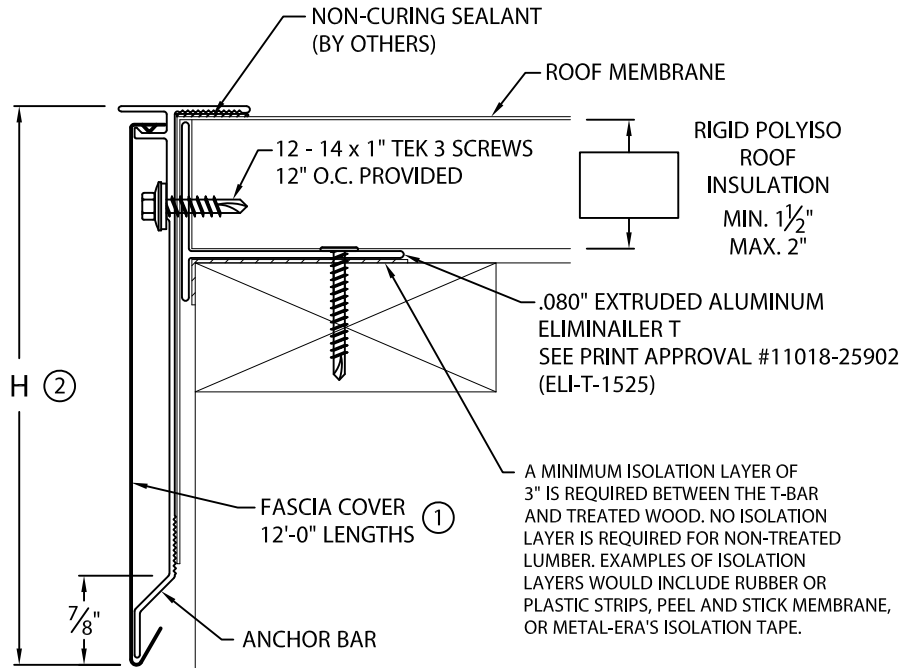

ANCHOR-TITE DRIP EDGE FOR USE WITH ELIMINAILER[®]-T

1.5" ELIMINAILER VERSION
FOR USE WITH WOOD NAILER

U.S. PATENT # 9,878,023 B1



NOTES:

- (1) FASCIA COVER PROVIDED WITH 1" LAP JOINTS.
- (2) TYPICALLY COVERAGE SHOULD EXTEND A MIN. OF 1 1/2" BELOW WOOD BLOCKING IF APPLICABLE.

DRIP EDGE COVER MATERIAL:

- ___ 24 GA. GALVANIZED STEEL
- ___ .040" ALUMINUM
- ___ OTHER _____

COLOR: _____

FINISH: _____

ANCHOR-TITE DRIP EDGE DIMENSIONS

PRODUCT ID. NO.	H DIM
<input type="checkbox"/> T-AFDE-60	6"
<input type="checkbox"/> T-AFDE-75	7 1/2"

QUANTITIES:

- _____ LINEAL FEET 12'-0" LENGTHS
- _____ OUTSIDE MITER(S) @ 90°
- _____ INSIDE MITER(S) @ 90°

FOR NON-90 MITERS SEE PRINT APPROVAL #11010-1103

Fabrication will proceed only after receipt of signed print approval.

Print Approval:

Architect and/or contractor shall verify all dimensions, sizes and quantities. All products to be installed in strict accordance with Metal-Era's printed instructions.

Approved by: _____

Date: _____

PROJECT:

ARCHITECT:

ROOFING CONTRACTOR:

REPRESENTATIVE/DISTRIBUTOR:

Corporate Offices, Manufacturing
1600 Airport Road; Waukesha, WI 53188
Phone: 800-558-2162
Fax: 800-373-9156
www.metalera.com



DATE: 03/20/18

DRN BY: JJC

CKD BY: SAK

SHT.# ___ OF ___

DWG# 11010-26092

A

ELIMINAILER®-T

FOR USE WITH EXISTING WOOD NAILER, 1.5" VERSION

U.S. PATENT # 9,878,023 B1

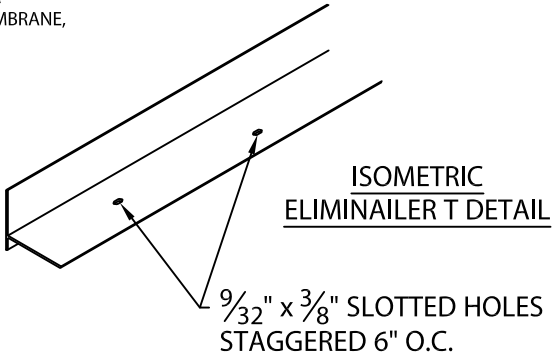
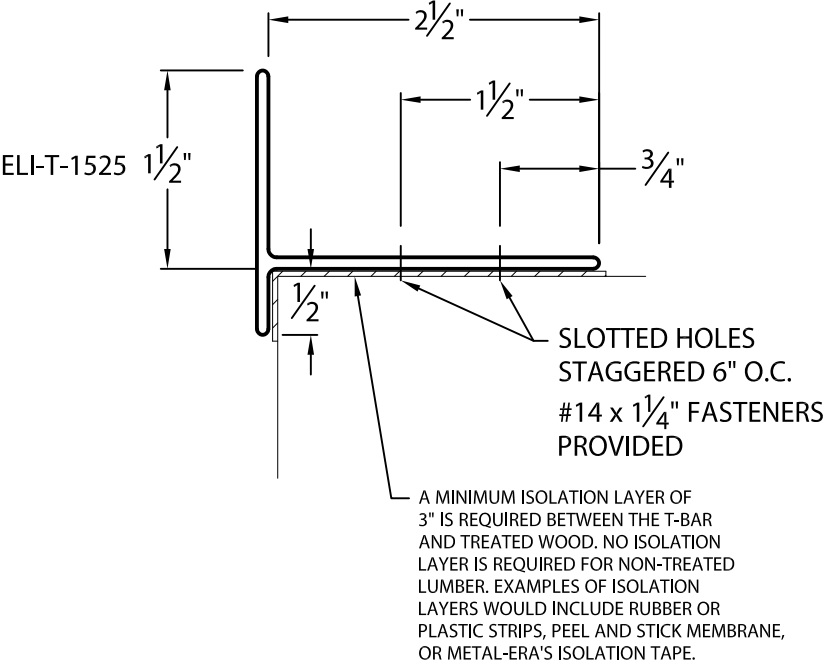

Fabrication will proceed only after receipt of signed print approval.

Print Approval:

Architect and/or contractor shall verify all dimensions, sizes and quantities. All products to be installed in strict accordance with Metal-Era's printed instructions.

Approved by: _____
Date: _____

MATERIAL:

.080" EXTRUDED ALUMINUM

QUANTITIES:

_____ LINEAL FEET 12'-0" LENGTHS
_____ ROLLS ISOLATION TAPE 3" WIDE (180 FT PER ROLL)

PROJECT:	Corporate Offices, Manufacturing 1600 Airport Road; Waukesha, WI 53188 Phone: 800-558-2162 Fax: 800-373-9156 www.metalera.com
ARCHITECT:	
ROOFING CONTRACTOR:	
REPRESENTATIVE/DISTRIBUTOR:	



DATE: 03/20/18	SHT.# _____ OF _____
DRN BY: JJC	DWG# 11018-25902
CKD BY: SAK	