

CREATIVE DESIGN BULLNOSE COPING

2'-0" O.C.

INSTALLATION INSTRUCTIONS

IMPORTANT: Prior to installation, read instructions carefully.

NOTE: Position roof membrane on top of the wall covering the treated wood nailer(s) or substrate completely. Allow 1/2" (13 mm) minimum excess membrane beyond nailer where applicable. NRCA requirement.

CAUTION: INSTALL MITERS FIRST!

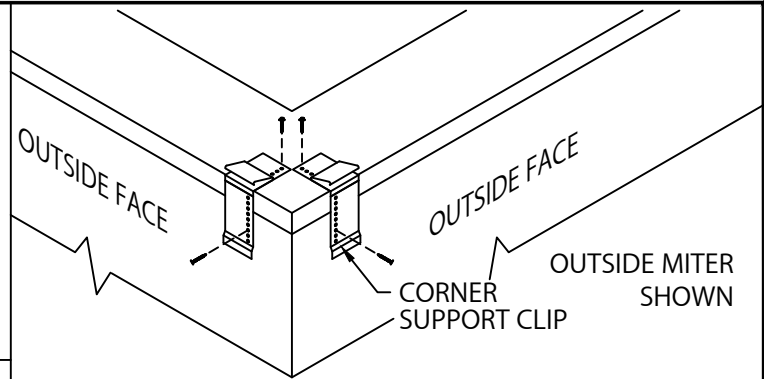

STEP 1 - CORNER SUPPORT CLIPS
LOCATE AND FASTEN GALVANIZED CORNER CLIPS TO TO THE WALL.

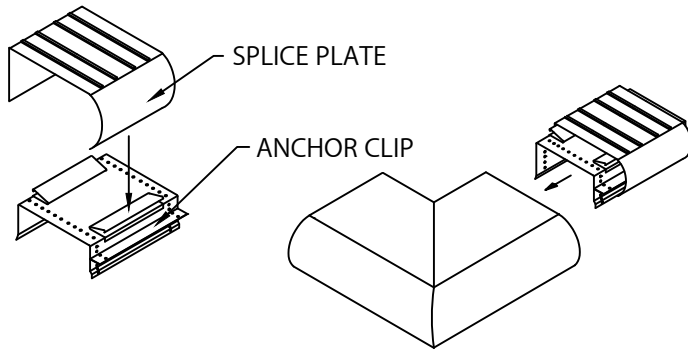

STEP 2 - MITER SPLICE PLATES & ANCHOR CLIPS
POSITION THE SPLICE PLATE IN THE CENTER OF THE ANCHOR CLIP. INSTALL THE SPLICE PLATE AND ANCHOR CLIP ASSEMBLY INTO EACH END OF THE CORNER AS SHOWN

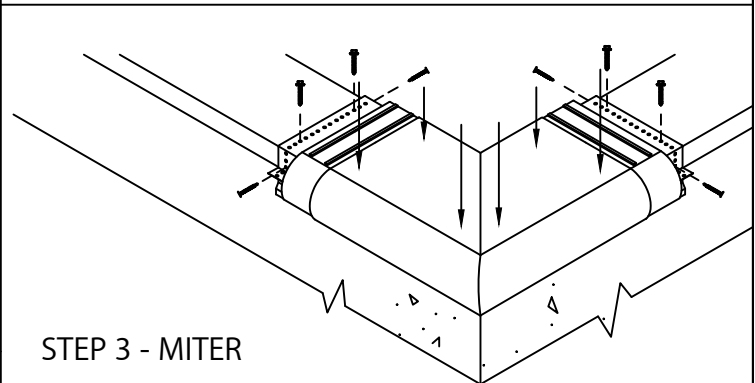

STEP 3 - MITER
PLACE THE CORNER ASSEMBLY INTO POSITION AND SECURE AT THE EXPOSED EDGE OF THE ANCHOR CLIPS AS PER DETAIL A.

LEFT ENDCAP SHOWN

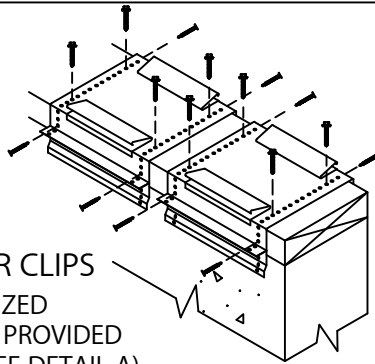

STEP 4 - ENDCAP ANCHOR CLIPS
LOCATE AND FASTEN GALVANIZED ANCHOR CLIPS TO WALL WITH PROVIDED FASTENERS FOR SUBSTRATE (SEE DETAIL A).

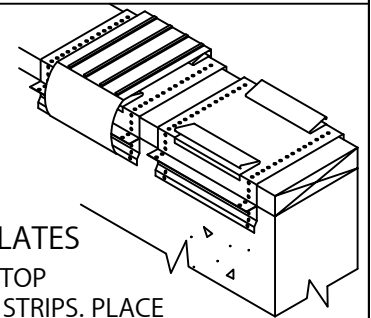

STEP 5 - ENDCAP SPLICE PLATES
REMOVE RELEASE PAPER FROM TOP OF FACTORY APPLIED SEALANT STRIPS. PLACE SPLICE PLATE ONTO SECOND ANCHOR CLIP AS SHOWN.

STEP 6 - ENDCAP

HOOK OUTSIDE FACE OF ENDCAP OVER THE ANCHOR CLIPS AND ROTATE INTO PLACE. ENGAGE REAR LEG ONTO ANCHOR CLIPS BY PRESSING DOWNWARD UNTIL SNAP LOCK OCCURS.

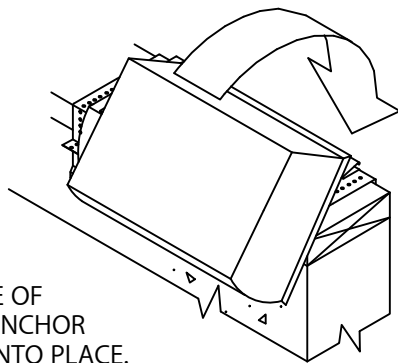

DETAIL A - ANCHOR CLIP FASTENING

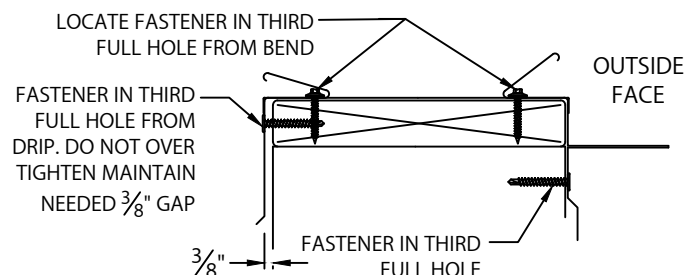

Phone: 800-558-2162
Fax: 800-373-9156
www.metalera.com

DATE: 07/06/23
DRN BY: MLM
CKD BY: MM

SHT.# 1 OF 2
DWG# 11111-41069

A

CREATIVE DESIGN BULLNOSE COPING

2'-0" O.C.

INSTALLATION INSTRUCTIONS

INSTALLATION NOTES:

1) Installing contractor shall check as-built conditions, including nailer attachment, and verify the manufacturer's coping details for accuracy to fit the wall assembly prior to fabrication.

2) Fasteners must be corrosion resistant and rated for a minimum 250# pullout force for the substrate that is being used.

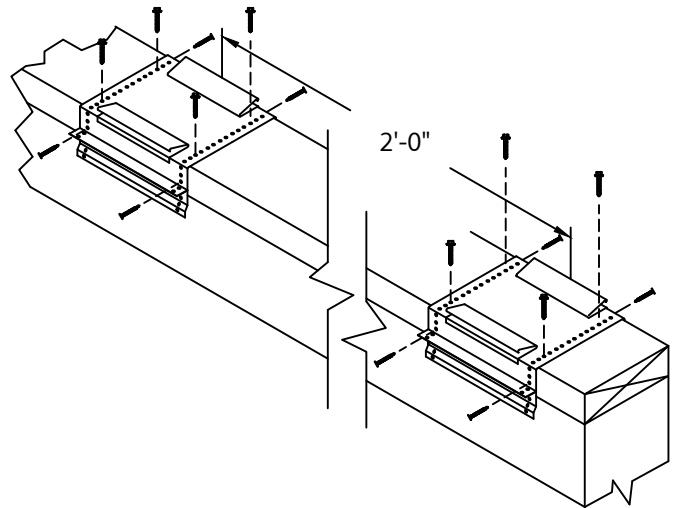
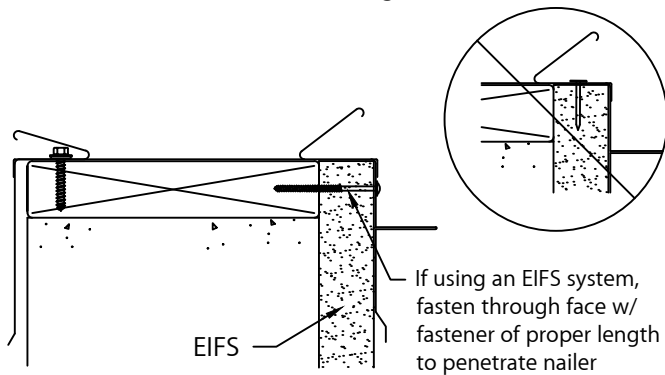

STEP 7 - ANCHOR CLIPS

LOCATE AND FASTEN GALVANIZED ANCHOR CLIPS TO WALL AT 2'-0" CENTERS WITH PROVIDED FASTENERS FOR SUBSTRATE (SEE DETAIL A).

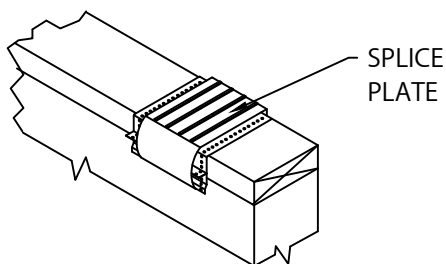

STEP 8 - SPLICE PLATES

PLACE SPLICE PLATE ONTO ANCHOR CLIPS AT SPLICE JOINTS, 4'-0" O.C.

NOTE: REMOVE RELEASE PAPER FROM SEALANT STRIPS.

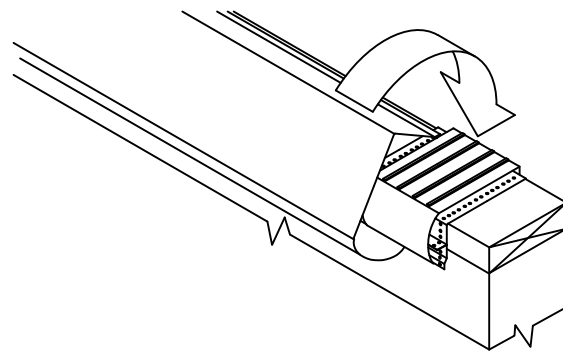

STEP 9 - COPING

HOOK OUTSIDE FACE OF COPING OVER THE ANCHOR CLIPS AND ROTATE INTO PLACE. ENGAGE REAR LEG ONTO ANCHOR CLIPS BY PRESSING DOWNWARD UNTIL SNAP LOCK OCCURS.

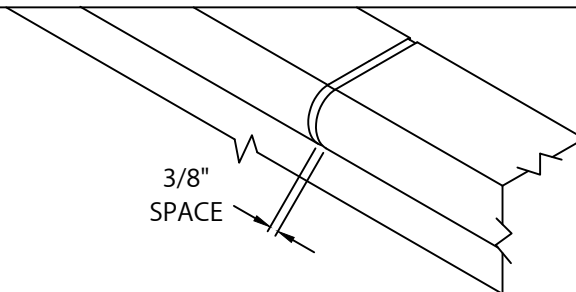

STEP 10 - COMPLETION

CONTINUE INSTALLING COPING WITH A 3/8" SPACE AT SPLICE JOINTS TO ALLOW FOR THERMAL EXPANSION. FIELD CUT WHERE NECESSARY USING FINE TOOTH HACKSAW OR SNIPS.

NOTE: REMOVE PROTECTIVE FILM IMMEDIATELY.

TYPICAL COPING INSTALLATION

8" WIDE SPLICE PLATES WITH DUAL NON-CURING SEALANT STRIPS AT EACH JOINT

12" WIDE GALVANIZED ANCHOR CLIPS 2'-0" O.C.

