

# DESCRIPTION: ONE GRAVEL STOP WITHOUT CONTINUOUS CLEAT

## INSTALLATION INSTRUCTIONS

NOTE: INSTALL MITERS FIRST.

IMPORTANT: PRIOR TO INSTALLATION, READ INSTRUCTIONS CAREFULLY.

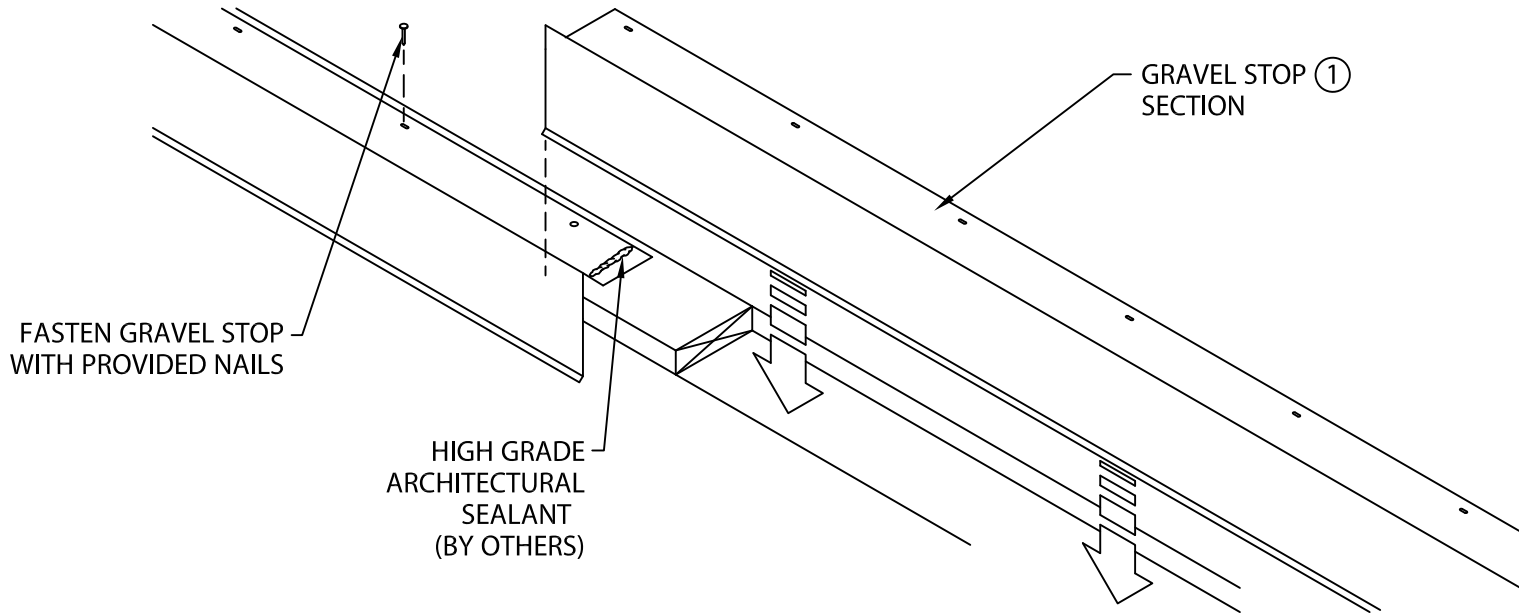

STEP ① POSITION GRAVEL STOP AND FASTEN EACH SECTION THROUGH HOLES PROVIDED 6" O.C. WITH PROVIDED NAILS. SEALANT (BY OTHERS) TO BE FIELD APPLIED AS SHOWN.

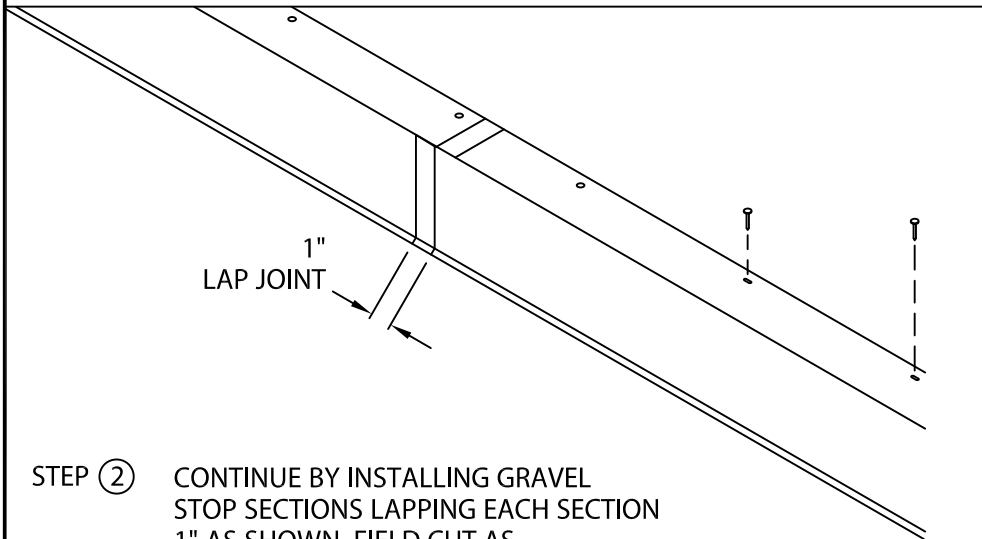

STEP ② CONTINUE BY INSTALLING GRAVEL STOP SECTIONS LAPPING EACH SECTION 1" AS SHOWN. FIELD CUT AS NECESSARY WITH FINE TOOTH HACKSAW.

CAUTION: REMOVE PROTECTIVE FILM IMMEDIATELY AFTER INSTALLATION. INSTALLERS SHALL WEAR PROTECTIVE EYEWEAR TO PREVENT INJURY.

## TYPICAL INSTALLATION

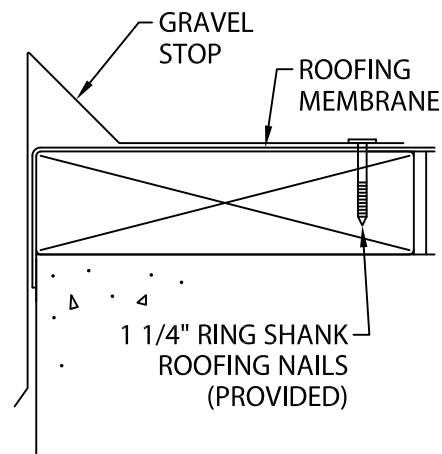

**ONE** Edge Systems  
ECONOMICAL | FAST | TESTED

TODAY'S ANSWER TO  
AN ECONOMICAL  
ROOF EDGE SYSTEM

EDGE SYSTEMS ONE  
CORPORATE OFFICE:

CUSTOMER SERVICE:  
800-558-2162

FAX:  
800-373-9156

WEB SITE:  
METALERA.COM

DATE: 09/26/18

DWN BY: JJC

SHEET: \_\_\_ OF \_\_\_

DWG: 24110-4766 | D