

# SEAL-TITE GOLD INDUSTRIAL GUTTER FOR USE WITH ELIMINAILER®-T

IGG-2 GUTTER, 5.2", 4" FLANGE ELIMINAILER VERSION

FOR USE WITH MASONRY WALL

U.S. PATENT # 9,878,023 B1

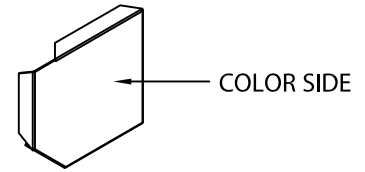
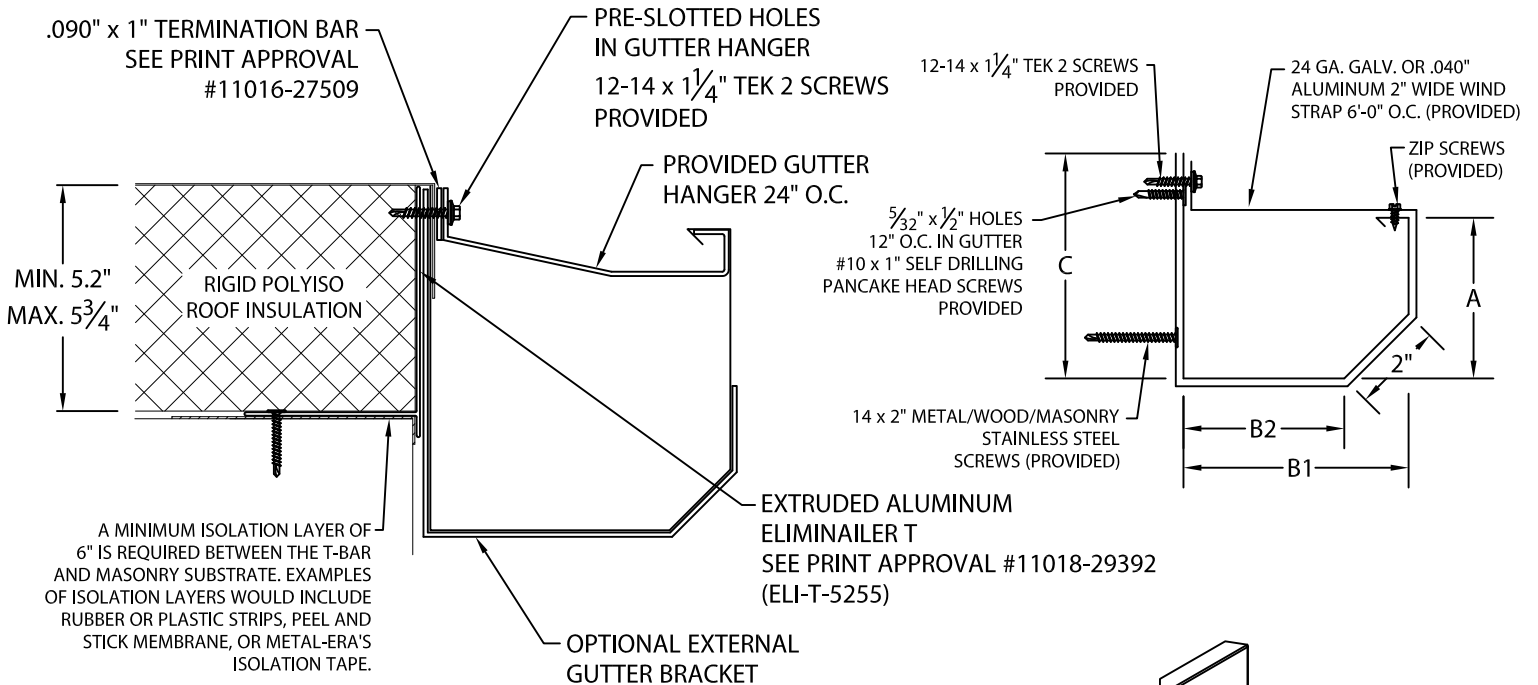

ENDCAP DETAIL  
(LEFT HAND SHOWN)

PRODUCT ID #	C	B1	B2	A
<input type="checkbox"/> T-IGG2-C8	8"	7"	5 9/16"	7"
<input type="checkbox"/> T-IGG2-C9	9"	8"	6 9/16"	8"

**NOTES:**

- MAXIMUM DOWNSPOUT DIMENSION NOT TO EXCEED "B2" MINUS 9/16".
- 6" WIDE SPLICE PLATES PROVIDED.
- 1/8" STAINLESS STEEL POP RIVETS PROVIDED.
- UNLESS OTHERWISE NOTED, FABRICATION OF MITERS ARE FURNISHED STANDARD UTILIZING A NON-PENETRATING QUICKLOCK JOINT, THEN FACTORY SEALED WATERTIGHT.
- WELDED ACCESSORIES REQUIRE A MINIMUM MATERIAL THICKNESS OF .050".

Fabrication will proceed only after receipt of signed print approval.

**Print Approval:**

Architect and/or contractor shall verify all dimensions, sizes and quantities. All products to be installed in strict accordance with Metal-Era's printed instructions.

Approved by: \_\_\_\_\_

Date: \_\_\_\_\_

**MATERIAL:**

- \_\_\_ 24 GA. GALVANIZED STEEL
- \_\_\_ .040" ALUMIINIUM COLOR: \_\_\_\_\_
- \_\_\_ .050" ALUMINIUM FINISH: \_\_\_\_\_
- \_\_\_ .063" ALUMINIUM
- \_\_\_ OTHER \_\_\_\_\_

**QUANTITIES:**

- \_\_\_ LINEAL FEET 12'-0" LENGTHS
  - \_\_\_ OUTSIDE MITERS @ 90°
  - \_\_\_ INSIDE MITERS @ 90°
  - \_\_\_ RIGHT ENDCAPS
  - \_\_\_ LEFT ENDCAPS
  - \_\_\_ EXPANSION JOINTS STYLE "1"
  - \_\_\_ EXPANSION JOINTS STYLE "2"
- SPECIFY MITER TYPE:  
 WELDED  
 QUICKLOCK

FOR NON-90 MITERS SEE PRINT APPROVAL #11012-10010

PROJECT:	Corporate Offices, Manufacturing 1600 Airport Road; Waukesha, WI 53188 Phone: 800-558-2162 Fax: 800-373-9156 www.metalera.com
ARCHITECT:	
ROOFING CONTRACTOR:	
REPRESENTATIVE/DISTRIBUTOR:	



DATE: 05/22/19	SHT.# _____ OF _____
DRN BY: ZS	DWG# 11012-29718 <b>B</b>
CKD BY: JAI	

# ELIMINAILER®-T

FOR USE WITH MASONRY WALL, 5.2", 4" FLANGE VERSION

U.S. PATENT # 9,878,023 B1

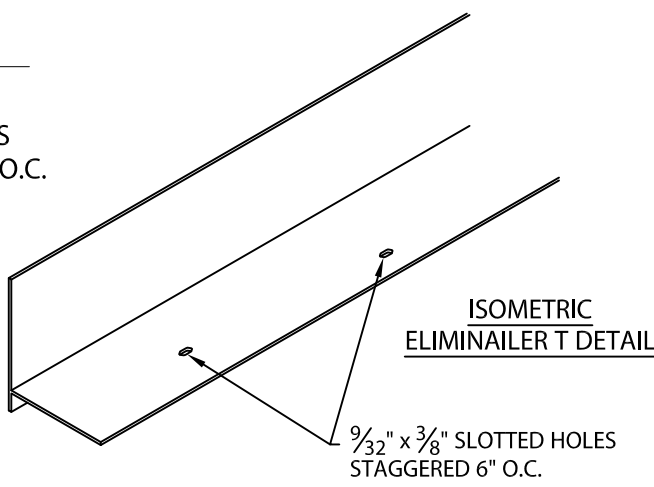
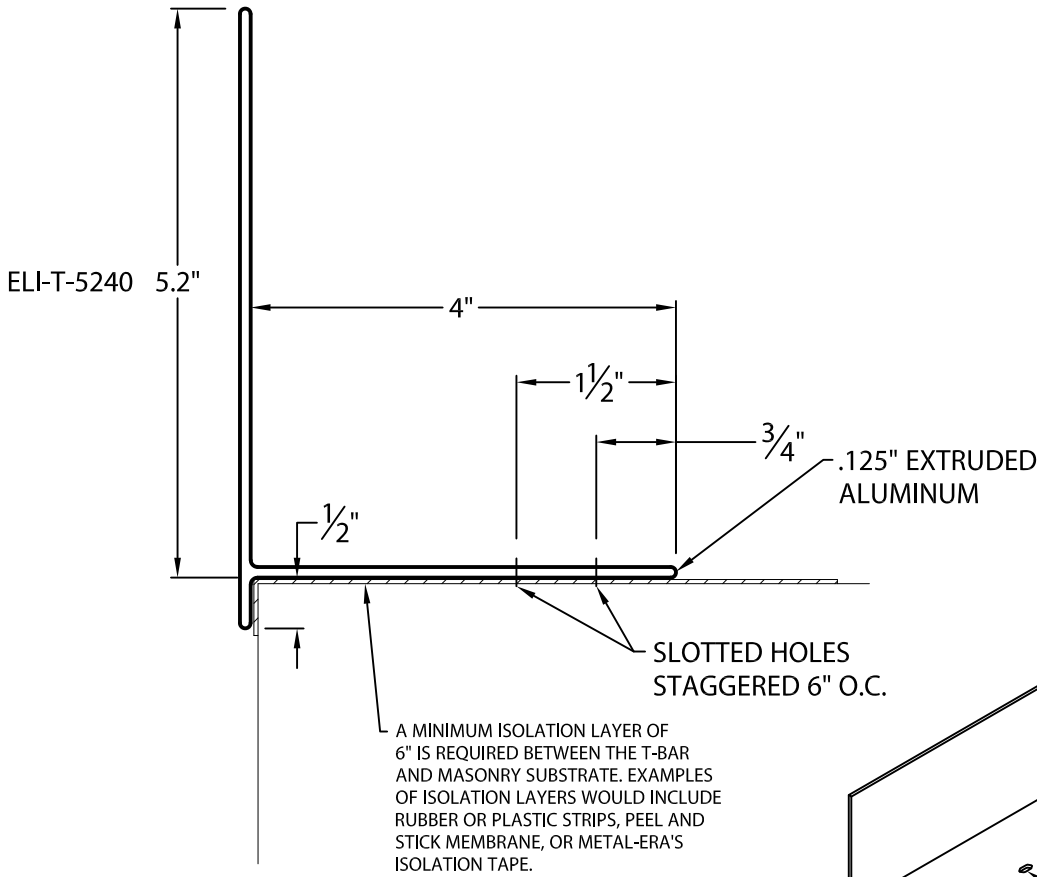

Fabrication will proceed only after receipt of signed print approval.

## Print Approval:

Architect and/or contractor shall verify all dimensions, sizes and quantities. All products to be installed in strict accordance with Metal-Era's printed instructions.

Approved by: \_\_\_\_\_  
Date: \_\_\_\_\_

- PLEASE INDICATE SUBSTRATE (IF SUBSTRATE INFORMATION IS NOT GIVEN, CONCRETE WALL FASTENERS WILL BE PROVIDED)
- CONCRETE WALL (3000 PSI CONCRETE):  
#14 x 1 1/4" FASTENERS PROVIDED
  - CMU WALL (1500 PSI):  
1/4" x 1 1/2" SPIKE FASTENERS PROVIDED

### QUANTITIES:

\_\_\_\_\_ LINEAL FEET 12'-0" LENGTHS  
\_\_\_\_\_ ROLLS ISOLATION TAPE 6" WIDE (180 FT PER ROLL)

PROJECT:	Corporate Offices, Manufacturing 1600 Airport Road; Waukesha, WI 53188 Phone: 800-558-2162 Fax: 800-373-9156 www.metalera.com
ARCHITECT:	
ROOFING CONTRACTOR:	
REPRESENTATIVE/DISTRIBUTOR:	



DATE: 07/30/18	SHT.# _____ OF _____
DRN BY: JJC	DWG# 11018-29392
CKD BY: SAK	

# TERMINATION BAR

CB-90

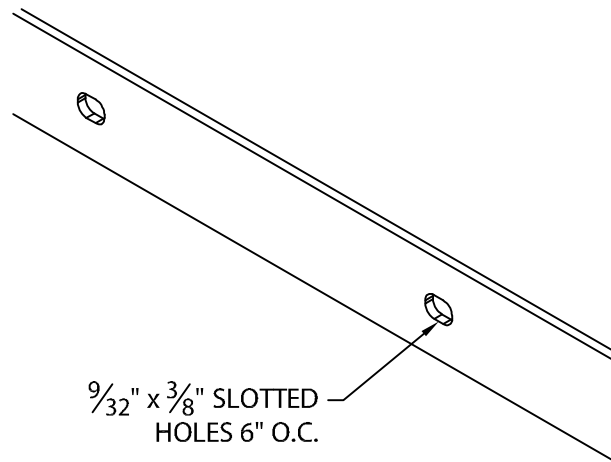
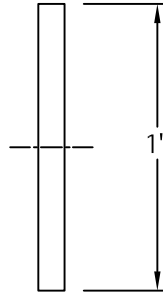

Fabrication will proceed only after receipt of signed print approval.

## Print Approval:

Architect and/or contractor shall verify all dimensions, sizes and quantities. All products to be installed in strict accordance with Metal-Era's printed instructions.

Approved by: \_\_\_\_\_

Date: \_\_\_\_\_

## MATERIAL:

.090" ALUMINUM

## QUANTITIES:

\_\_\_\_\_ LINEAL FEET 12'-0" LENGTHS

PROJECT:

ARCHITECT:

ROOFING CONTRACTOR:

REPRESENTATIVE/DISTRIBUTOR:

Corporate Offices, Manufacturing  
1600 Airport Road; Waukesha, WI 53188  
Phone: 800-558-2162  
Fax: 800-373-9156  
www.metalera.com



DATE: 11/09/17

DRN BY: JJC

CKD BY: SAK

SHT.# \_\_\_\_ OF \_\_\_\_

DWG# 11016-27509

A