

SEAL-TITE INDUSTRIAL GUTTER FOR USE WITH ELIMINAILER®-T

IG-2 GUTTER, 5.2", 4" FLANGE ELIMINAILER VERSION

FOR USE WITH METAL DECK

U.S. PATENT # 9,878,023 B1

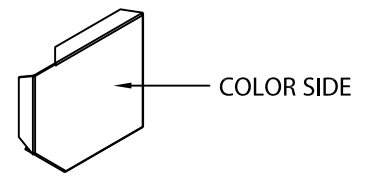
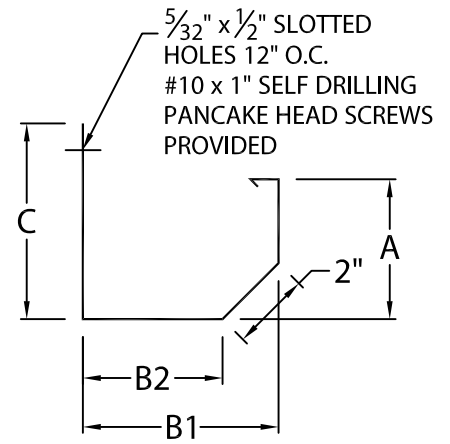
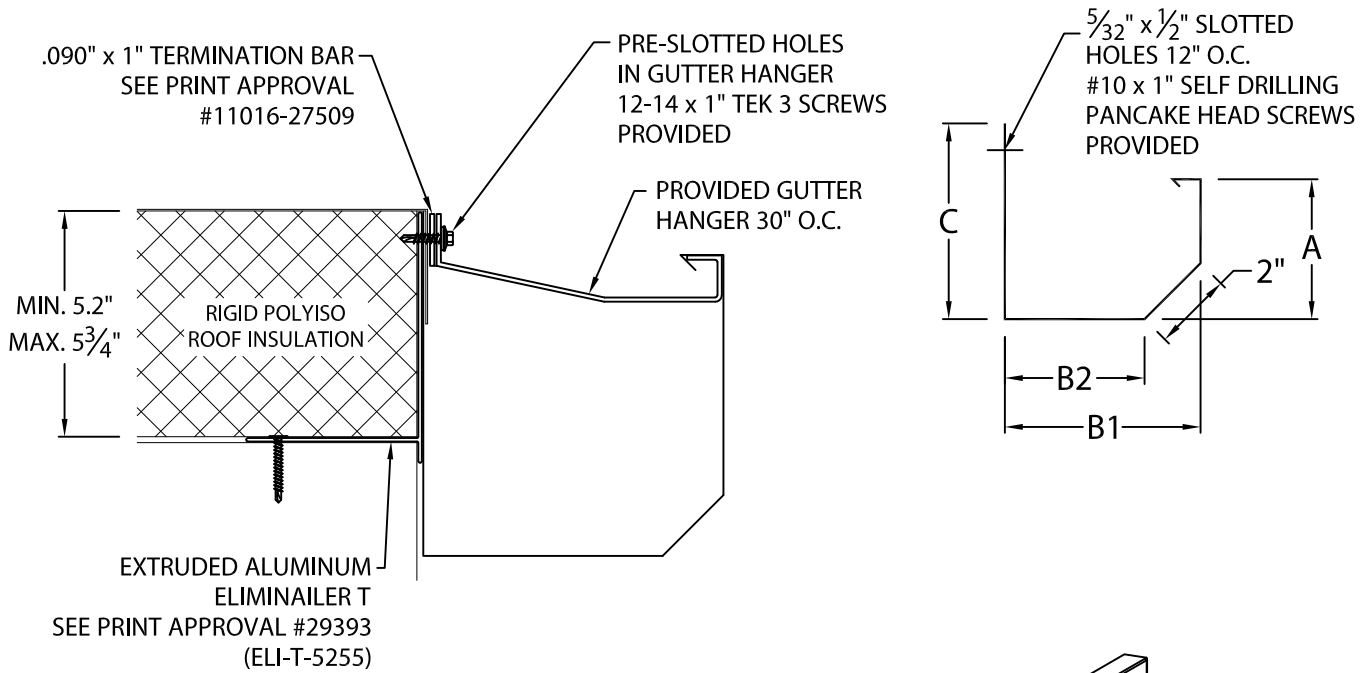

ENDCAP DETAIL (LEFT HAND SHOWN)

PRODUCT ID #	C	B1	B2	A	HANGER
<input type="checkbox"/> T-IG2-C8	8"	7"	5 9/16"	7"	2" X .100 Mill
<input type="checkbox"/> T-IG2-C9	9"	8"	6 9/16"	8"	2" X .100 Mill

NOTES:

- MAXIMUM DOWNSPOUT DIMENSION NOT TO EXCEED "B2" MINUS 9/16".
- 2" LAP JOINTS PROVIDED.
- 1/8" STAINLESS STEEL POP RIVETS PROVIDED.
- UNLESS OTHERWISE NOTED, FABRICATION OF MITERS ARE FURNISHED STANDARD UTILIZING A NON-PENETRATING QUICKLOCK JOINT, THEN FACTORY SEALED WATERTIGHT.
- WELDED ACCESSORIES REQUIRE A MINIMUM MATERIAL THICKNESS OF .050".

Fabrication will proceed only after receipt of signed print approval.

Print Approval:

Architect and/or contractor shall verify all dimensions, sizes and quantities. All products to be installed in strict accordance with Metal-Era's printed instructions.

Approved by: _____
Date: _____

MATERIAL:

- ___ 24 GA. GALVANIZED STEEL
- ___ .040" ALUMIINUM COLOR: _____
- ___ .050" ALUMINUM FINISH: _____
- ___ .063" ALUMINUM
- ___ OTHER _____

QUANTITIES:

- ___ LINEAL FEET 12'-0" LENGTHS
 - ___ OUTSIDE MITERS @ 90°
 - ___ INSIDE MITERS @ 90°
 - ___ RIGHT ENDCAPS
 - ___ LEFT ENDCAPS
 - ___ EXPANSION JOINTS STYLE "1"
 - ___ EXPANSION JOINTS STYLE "2"
- SPECIFY MITER TYPE:
 WELDED
 QUICKLOCK

FOR NON-90 MITERS SEE PRINT APPROVAL #11012-10010

PROJECT:	Corporate Offices, Manufacturing 1600 Airport Road; Waukesha, WI 53188 Phone: 800-558-2162 Fax: 800-373-9156 www.metalera.com
ARCHITECT:	
ROOFING CONTRACTOR:	
REPRESENTATIVE/DISTRIBUTOR:	



DATE: 09/08/18	SHT.# _____ OF _____
DRN BY: JJC	DWG# 11012-29711
CKD BY: SAK	