

# STEP-UP COPING MITERS

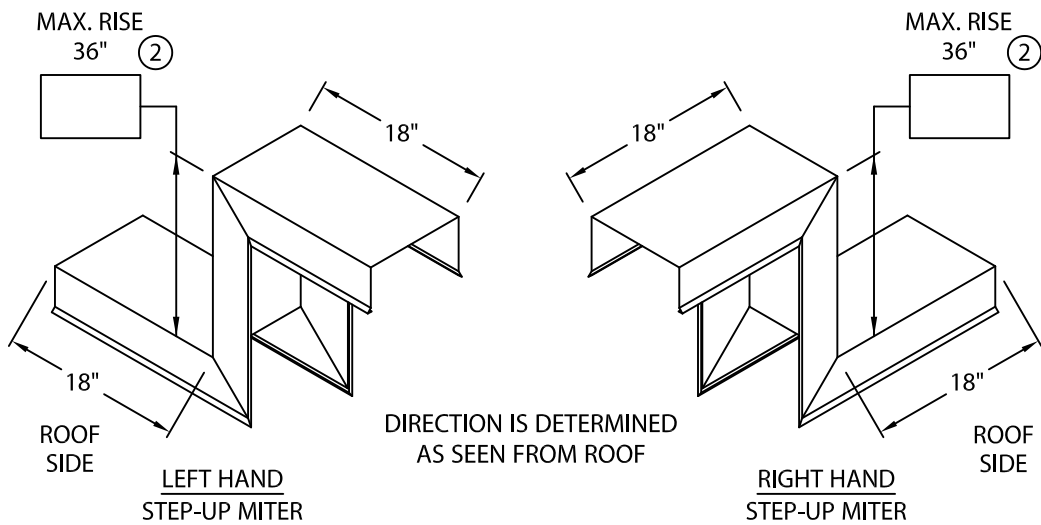

FOR CUSTOM LEG LENGTHS  
MODIFY DRAWINGS ABOVE

PEAK AND VALLEY MITERS  
(SEE NOTES 2 & 3)

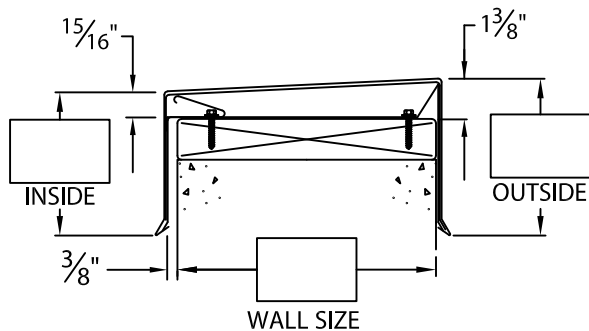
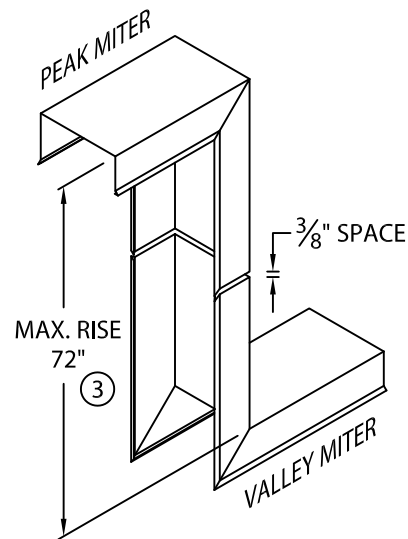

## NOTES:

- ① WELDED ACCESSORIES REQUIRE A MINIMUM MATERIAL THICKNESS OF .050".
- ② IF MAXIMUM RISE DIMENSION IS EXCEEDED, ACCESSORY WILL BE MANUFACTURED AS ONE 90° PEAK MITER AND ONE 90° VALLEY MITER.
- ③ IF RISE EXCEEDS 72", A STRAIGHT LENGTH WILL BE REQUIRED AND THE PEAK AND VALLEY MITERS REVERT BACK TO STANDARD 18" LENGTHS.

AUTHORIZED SIGNATURE: \_\_\_\_\_

APPROVED BY: \_\_\_\_\_

DATE: \_\_\_\_\_

## MATERIAL:

- \_\_\_ 24 GA. GALVANIZED STEEL
- \_\_\_ 22 GA. GALVANIZED STEEL
- \_\_\_ .040" ALUMINUM
- \_\_\_ .050" ALUMINUM
- \_\_\_ .063" ALUMINUM
- \_\_\_ OTHER \_\_\_\_\_

COLOR: \_\_\_\_\_

FINISH: \_\_\_\_\_

## QUANTITIES:

\_\_\_ RIGHT HAND STEP-UP MITER

\_\_\_ LEFT HAND STEP-UP MITER

SPECIFY ACCESSORY TYPE:

- WELDED ①
- QUICKLOCK

PROJECT: \_\_\_\_\_

ARCHITECT: \_\_\_\_\_

ROOFING CONTRACTOR: \_\_\_\_\_

REPRESENTATIVE/DISTRIBUTOR: \_\_\_\_\_

CORPORATE OFFICES, MANUFACTURING  
1600 AIRPORT ROAD; WAUKESHA, WI 53188  
PHONE: 800-558-2162  
FAX: 800-373-9156  
WEBSITE: WWW.METALERA.COM  
EMAIL: QUOTE@METALERA.COM



DATE: 9/27/2021

DRN BY: MLM

CKD BY: MM

SHT.# \_\_\_\_ OF \_\_\_\_

DWG# 11011-1494

G