

HI-PERF RAKE PANEL

WITHOUT VERTICAL "Z" BRACKETS

INSTALLATION INSTRUCTIONS

TYPICAL PANEL INSTALLATION

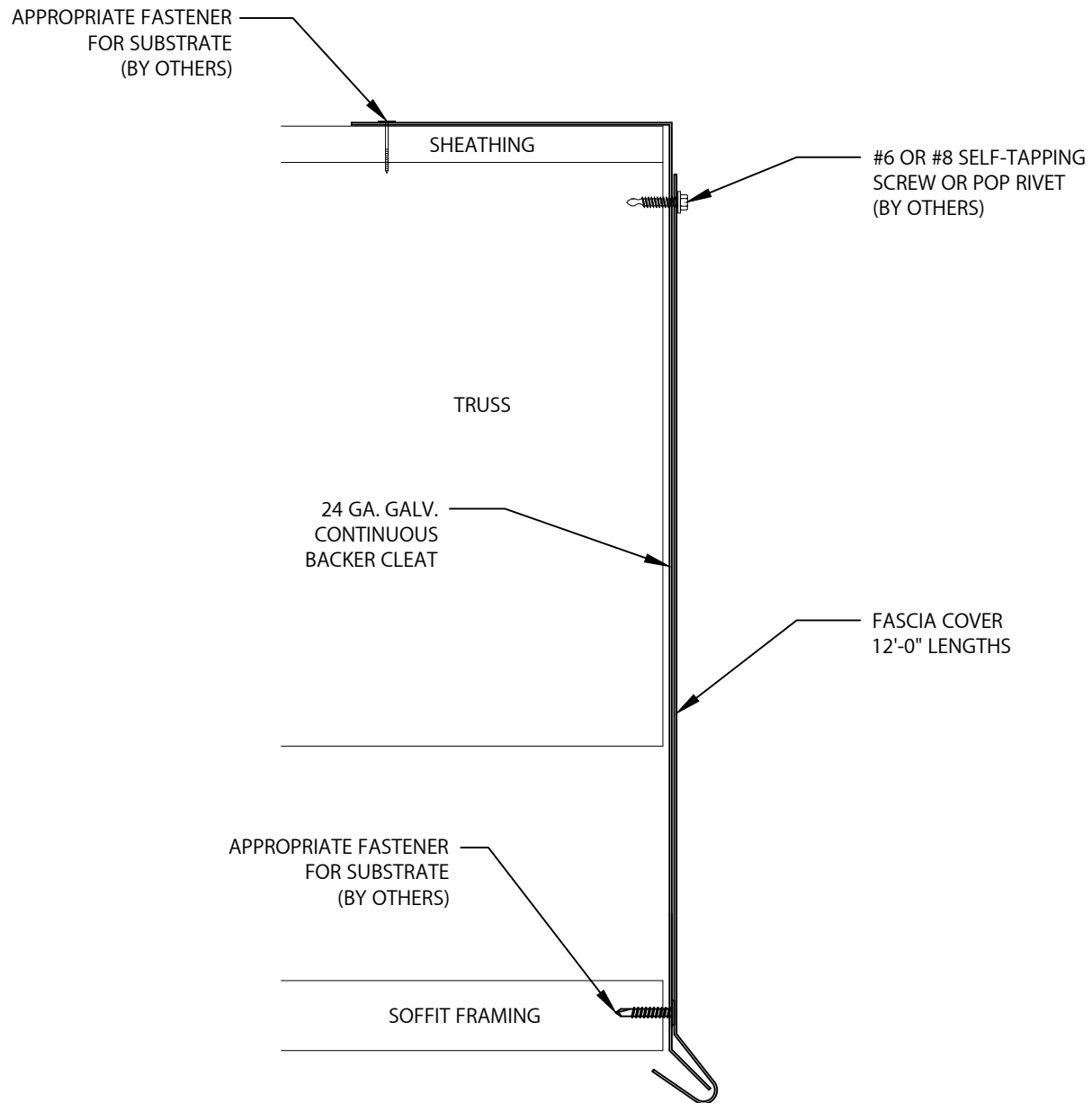

Phone: 800-558-2162
Fax: 800-770-3934
www.metalera.com

DATE: 09/27/22

SHT.# 1 OF 8

DRN BY: MLM

CKD BY: MM

DWG# 31127-7385

G

HI-PERF RAKE PANEL

WITHOUT VERTICAL "Z" BRACKETS

INSTALLATION INSTRUCTIONS

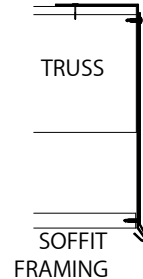
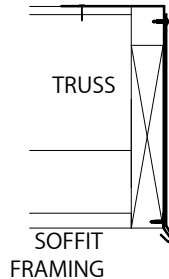
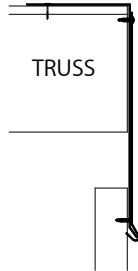

1. SUBSTRATE

SUBSTRATE MUST BE CONTINUOUS, FLAT, VERTICAL, AND ABLE TO SUPPORT FASTENERS WITH A MINIMUM 240 LB. PULL-OUT. EXAMPLES - ATTACHING FLUSH TO A WALL, TO A WOOD SUBSTRATE, TO SOFFIT FRAMING.

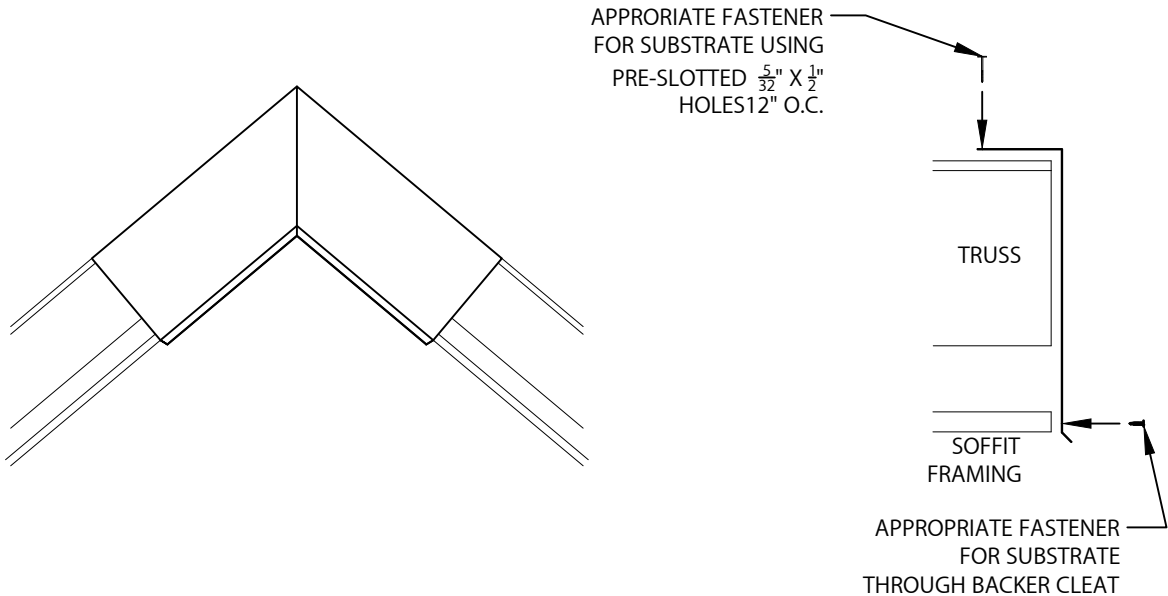

2A. MITER BACKER CLEAT ATTACHMENT - PEAK MITER SHOWN

ALIGN THE BACK OF THE BACKER CLEAT WITH THE TRUSS. ALIGN THE TOP OF THE BACKER CLEAT WITH THE TOP OF THE SHEATHING. ATTACH THE FLANGE OF THE BACKER CLEAT TO THE TOP OF THE SHEATHING WITH AN APPROPRIATE FASTENER FOR THE SUBSTRATE USING THE PRE-SLOTTED $\frac{5}{32}$ " X $\frac{1}{2}$ " HOLES AT 12" O.C. ATTACH THE BOTTOM OF THE BACKER CLEAT 12" O.C. USING APPROPRIATE FASTENER FOR SUBSTRATE.

NOTE: BE SURE TO CHECK AND MAKE SURE THE MITERS ARE PLUMB, LEVEL, AND CENTERED AT THE CORNER. IT MAY BE HELPFUL TO ATTACH THE MITER TO A STRAIGHT PIECE OF THE BACKER TO AID IN THE ALIGNMENT PROCESS.



Phone: 800-558-2162
Fax: 800-770-3934
www.metalera.com

DATE: 09/27/22

SHT.# 2 OF 8

DRN BY: MLM

CKD BY: MM

DWG# 31127-7385

G

HI-PERF RAKE PANEL

WITHOUT VERTICAL "Z" BRACKETS

INSTALLATION INSTRUCTIONS

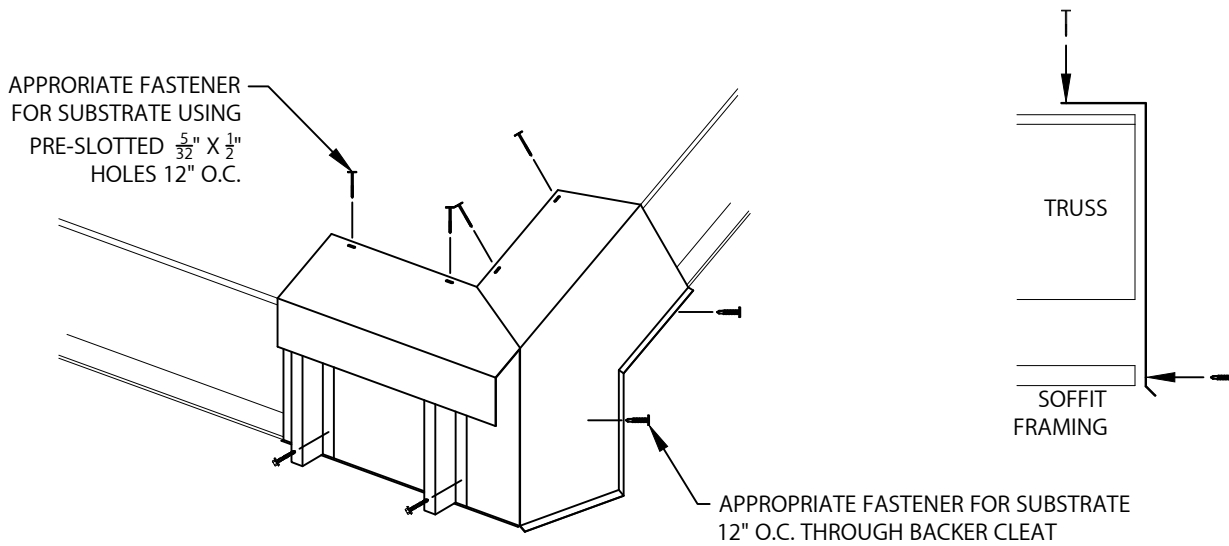

2B. MITER BACKER CLEAT ATTACHMENT - EAVE TO RAKE OUTSIDE MITER SHOWN

ALIGN THE BACK OF THE BACKER CLEAT WITH THE TRUSS. ALIGN THE TOP OF THE BACKER CLEAT WITH THE TOP OF THE SHEATHING. ATTACH THE FLANGE OF THE BACKER CLEAT TO THE TOP OF THE SHEATHING WITH AN APPROPRIATE FASTENER FOR THE SUBSTRATE USING THE PRE-SLOTTED $\frac{5}{32}$ " X $\frac{1}{2}$ " HOLES AT 12" O.C. ATTACH THE BOTTOM OF THE BACKER CLEAT 12" O.C. USING APPROPRIATE FASTENER FOR SUBSTRATE.

NOTE: BE SURE TO CHECK AND MAKE SURE THE MITERS ARE PLUMB, LEVEL, AND CENTERED AT THE CORNER. IT MAY BE HELPFUL TO ATTACH THE MITER TO A STRAIGHT PIECE OF THE BACKER TO AID IN THE ALIGNMENT PROCESS.

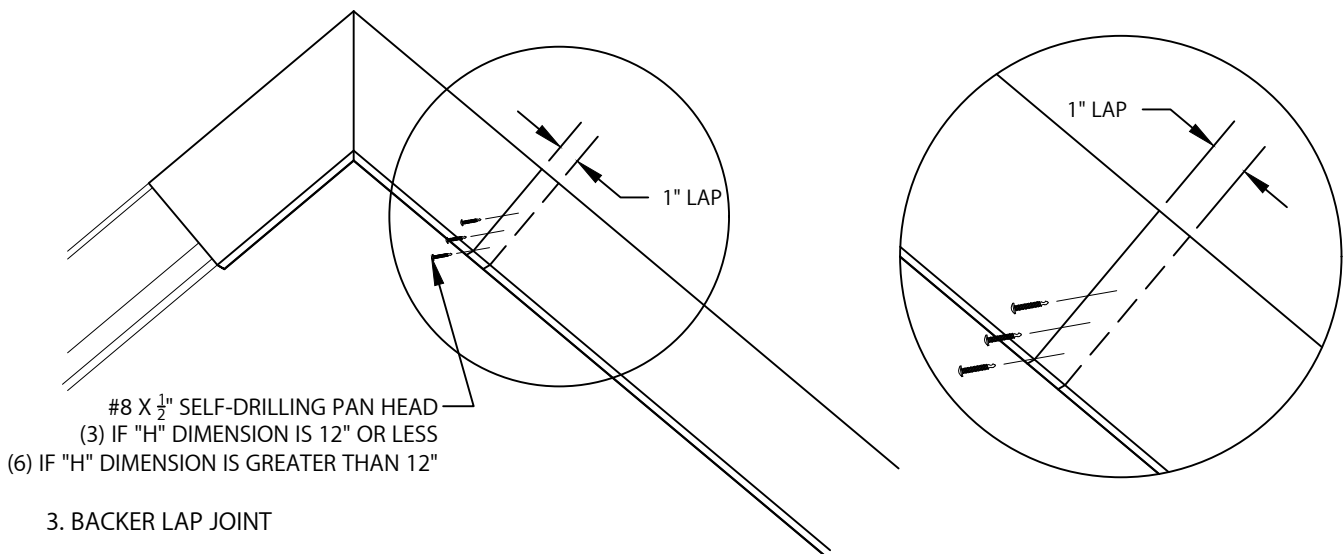

3. BACKER LAP JOINT

LAP ONE 12'-0" PIECE OF BACKER CLEAT 1" OVER THE MITER BACKER CLEAT AS SHOWN. FASTEN THE 24 GA. GALV. BACKER CLEAT OF THE 12'-0" PIECE TO THE 24 GA. GALV. BACKER CLEAT OF THE MITER USING #8 X $\frac{1}{2}$ " SELF-DRILLING PAN HEAD FASTENERS. USE 3 FASTENERS FOR "H" DIMENSIONS 12" OR LESS AND 6 FASTENERS FOR "H" DIMENSIONS GREATER THAN 12". NO FASTENERS NECESSARY AT THE BACKER CLEAT FLANGE LAP JOINT.



Phone: 800-558-2162
 Fax: 800-770-3934
www.metalera.com

DATE: 09/27/22	SHT.# 3 OF 8
DRN BY: MLM	DWG# 31127-7385
CKD BY: MM	

G

HI-PERF RAKE PANEL

WITHOUT VERTICAL "Z" BRACKETS

INSTALLATION INSTRUCTIONS

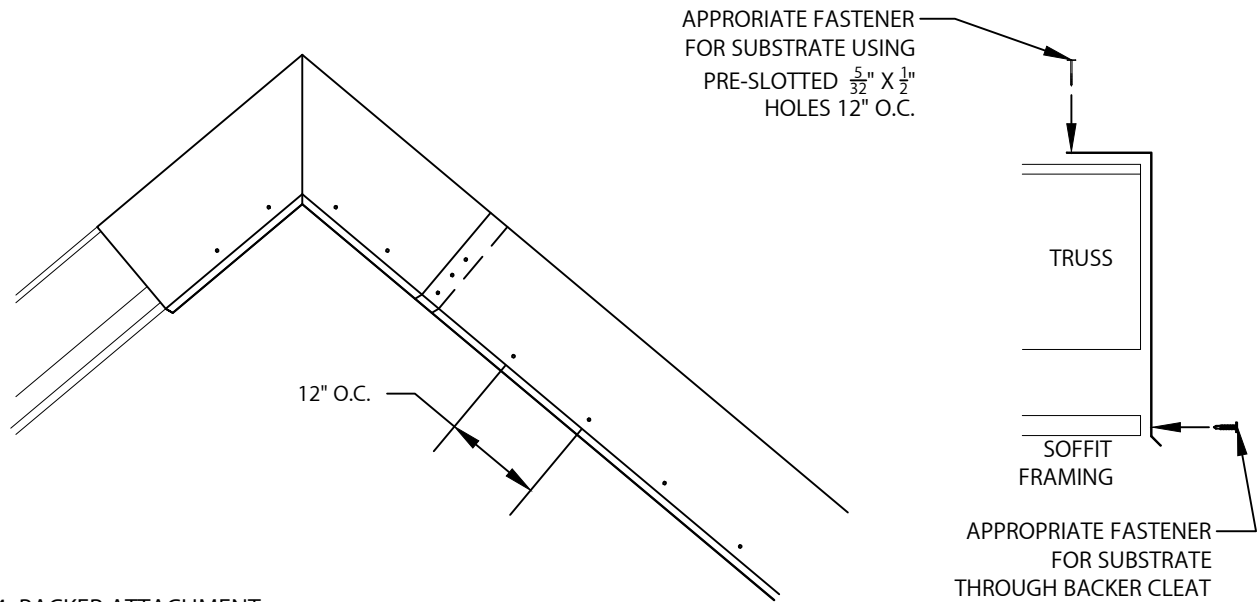

4. BACKER ATTACHMENT

ATTACH THE FLANGE OF THE BACKER CLEAT TO THE TOP OF THE SHEATHING WITH AN APPROPRIATE FASTENER FOR THE SUBSTRATE USING THE PRE-SLOTTED $\frac{5}{32}$ " X $\frac{1}{2}$ " HOLES AT 12" O.C. ATTACH THE BOTTOM OF THE BACKER CLEAT 12" O.C. USING APPROPRIATE FASTENER FOR SUBSTRATE.

CONTINUE WITH STEPS 5A-6 FOR LAP JOINT VERSION
GO TO STEPS 7A-8 FOR SPLICE PLATE VERSION

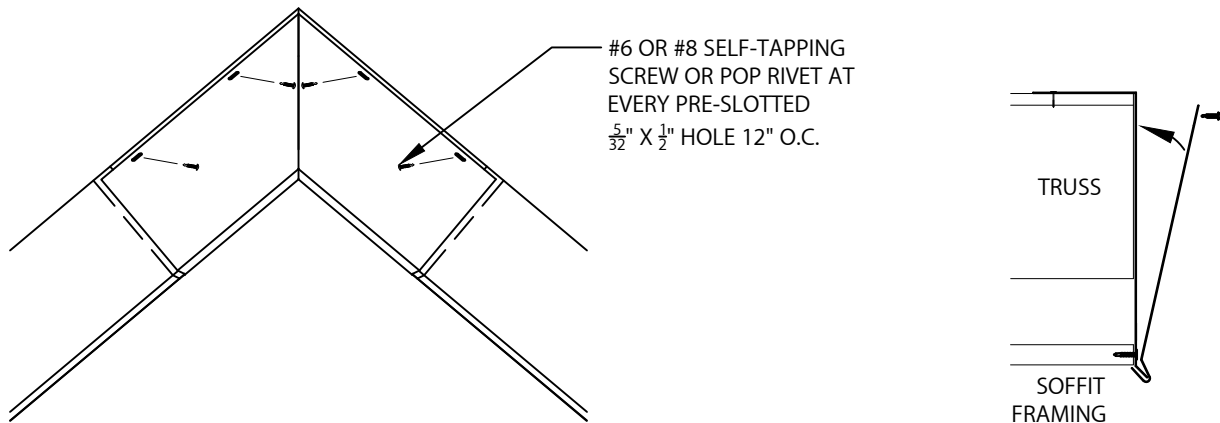

5A. MITER FASCIA COVER ATTACHMENT - PEAK MITER SHOWN LAP JOINT VERSION

HOOK THE BOTTOM OF THE MITER FASCIA COVER UNDER THE DRIP END OF THE BACKER CLEAT. ROTATE THE MITER FASCIA COVER AND FASTEN THE TOP OF THE MITER FASCIA COVER USING THE PRE-SLOTTED $\frac{5}{32}$ " X $\frac{1}{2}$ " HOLES AT 12" O.C. USING A #6 OR #8 SELF-TAPPING SCREW OR POP RIVET AT EVERY SLOTTED HOLE.



Phone: 800-558-2162
Fax: 800-770-3934
www.metalera.com

DATE: 09/27/22

SHT.# 4 OF 8

DRN BY: MLM

CKD BY: MM

DWG# 31127-7385

G

HI-PERF RAKE PANEL

WITHOUT VERTICAL "Z" BRACKETS

INSTALLATION INSTRUCTIONS

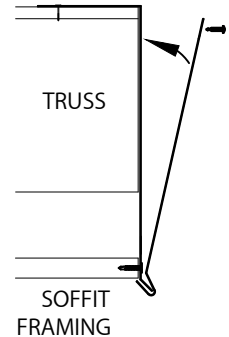
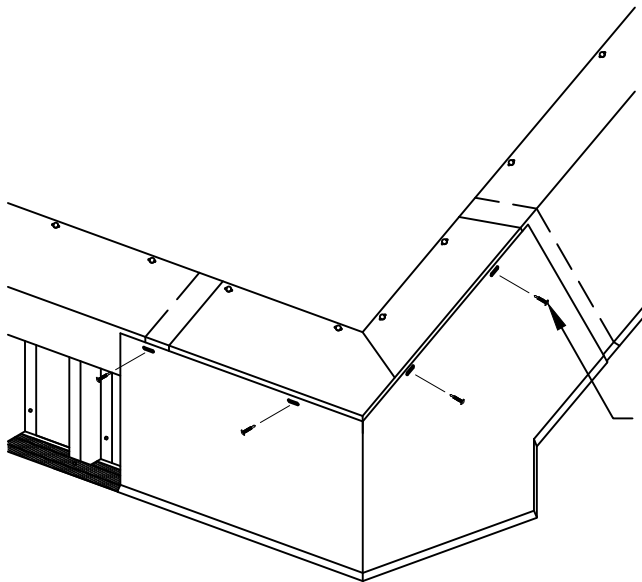

5B. MITER FASCIA COVER ATTACHMENT - EAVE TO RAKE OUTSIDE MITER SHOWN LAP JOINT VERSION

HOOK THE BOTTOM OF THE MITER FASCIA COVER UNDER THE DRIP END OF THE PERFORATED CLOSURE/BACKER CLEAT. ROTATE THE MITER FASCIA COVER AND FASTEN THE TOP OF THE MITER FASCIA COVER USING THE PRE-SLOTTED $\frac{5}{32}$ " X $\frac{1}{2}$ " HOLES AT 12" O.C. USING A #6 OR #8 SELF-TAPPING SCREW OR POP RIVET AT EVERY SLOTTED HOLE.

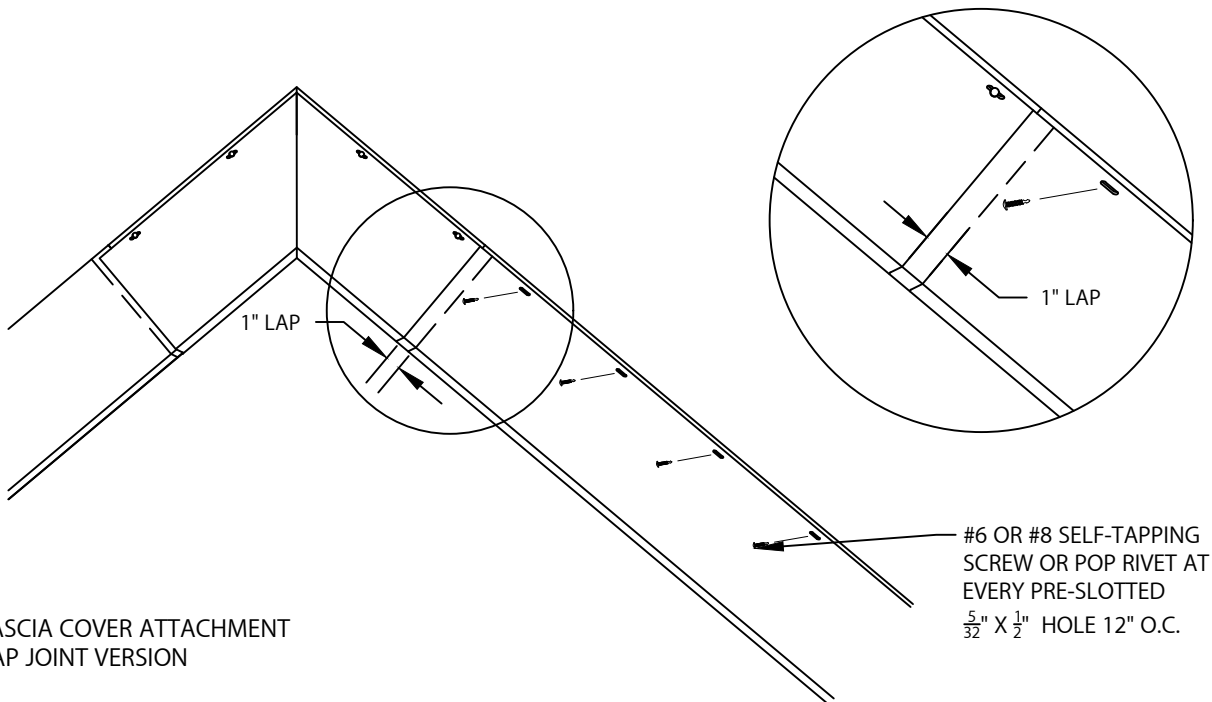

6. FASCIA COVER ATTACHMENT LAP JOINT VERSION

LAPPING ONE 12'-0" PIECE OF FASCIA COVER 1" OVER THE FASCIA COVER, HOOK THE BOTTOM OF THE FASCIA COVER UNDER THE DRIP END OF THE BACKER CLEAT. ROTATE THE FASCIA COVER AND FASTEN THE TOP OF THE COVER USING THE PRE-SLOTTED $\frac{5}{32}$ " X $\frac{1}{2}$ " HOLES AT 12" O.C. USING A #6 OR #8 SELF-TAPPING SCREW OR POP RIVET AT EVERY SLOTTED HOLE. NO FASTENERS NECESSARY AT THE CONTINUOUS FASCIA COVER LAP JOINT.



Phone: 800-558-2162
Fax: 800-770-3934
www.metalera.com

DATE: 09/27/22

SHT.# 5 OF 8

DRN BY: MLM

CKD BY: MM

DWG# 31127-7385

G

HI-PERF RAKE PANEL

WITHOUT VERTICAL "Z" BRACKETS

INSTALLATION INSTRUCTIONS

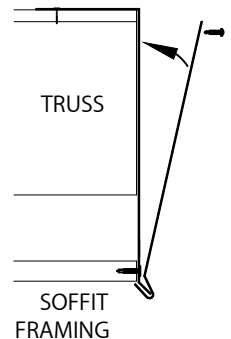
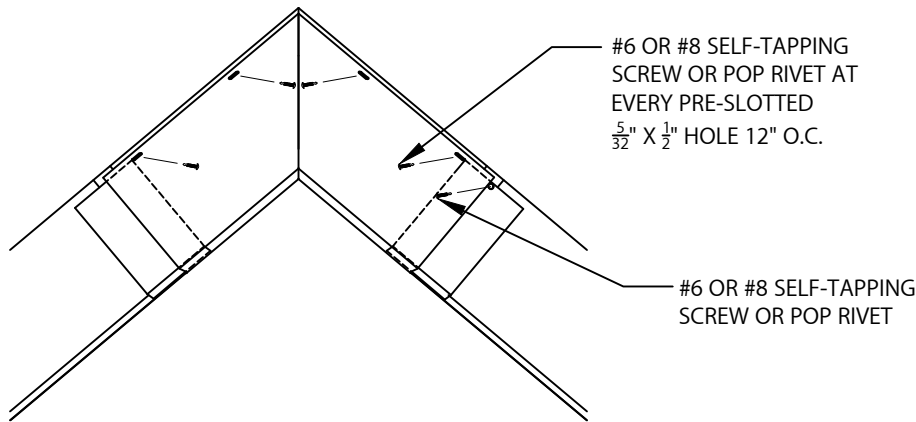

7A. MITER FASCIA COVER ATTACHMENT - PEAK MITER SHOWN SPLICE PLATE VERSION

POSITION $3\frac{1}{2}$ " SPLICE PLATE CENTERED BEHIND FASCIA COVER AS SHOWN (MITER FASCIA COVER SHOWN). USING #6 OR #8 SELF-TAPPING SCREW OR POP RIVET FASTEN THE TOP OF THE EXPOSED END OF THE SPLICE PLATE TO THE FACE OF THE CONTINUOUS BACKER CLEAT AS SHOWN. HOOK THE BOTTOM OF THE MITER FASCIA COVER UNDER THE DRIP END OF THE BACKER CLEAT. ROTATE THE MITER FASCIA COVER AND FASTEN THE TOP OF THE MITER FASCIA COVER USING THE PRE-SLOTTED $\frac{5}{32}$ " X $\frac{1}{2}$ " HOLES AT 12" O.C. USING A #6 OR #8 SELF-TAPPING SCREW OR POP RIVET AT EVERY SLOTTED HOLE.

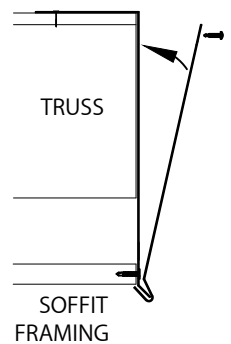
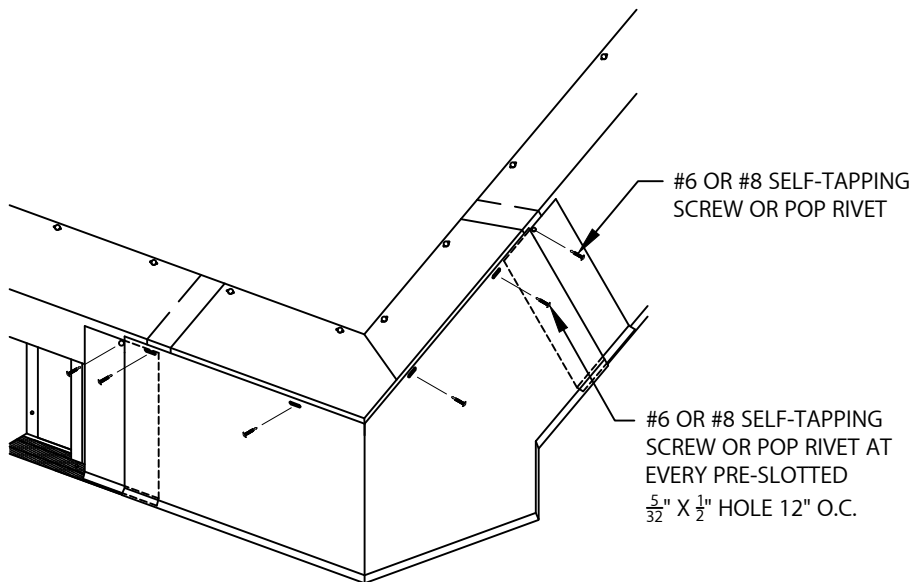

7B. MITER FASCIA COVER ATTACHMENT - EAVE TO RAKE OUTSIDE MITER SHOWN SPLICE PLATE VERSION

HOOK THE BOTTOM OF THE MITER FASCIA COVER UNDER THE DRIP END OF THE PERFORATED CLOSURE/BACKER CLEAT. ROTATE THE MITER FASCIA COVER AND FASTEN THE TOP OF THE MITER FASCIA COVER USING THE PRE-SLOTTED $\frac{5}{32}$ " X $\frac{1}{2}$ " HOLES AT 12" O.C. USING A #6 OR #8 SELF-TAPPING SCREW OR POP RIVET AT EVERY SLOTTED HOLE.



Phone: 800-558-2162
Fax: 800-770-3934
www.metalera.com

DATE: 09/27/22

SHT.# 6 OF 8

DRN BY: MLM

CKD BY: MM

DWG# 31127-7385

G

HI-PERF RAKE PANEL

WITHOUT VERTICAL "Z" BRACKETS

INSTALLATION INSTRUCTIONS

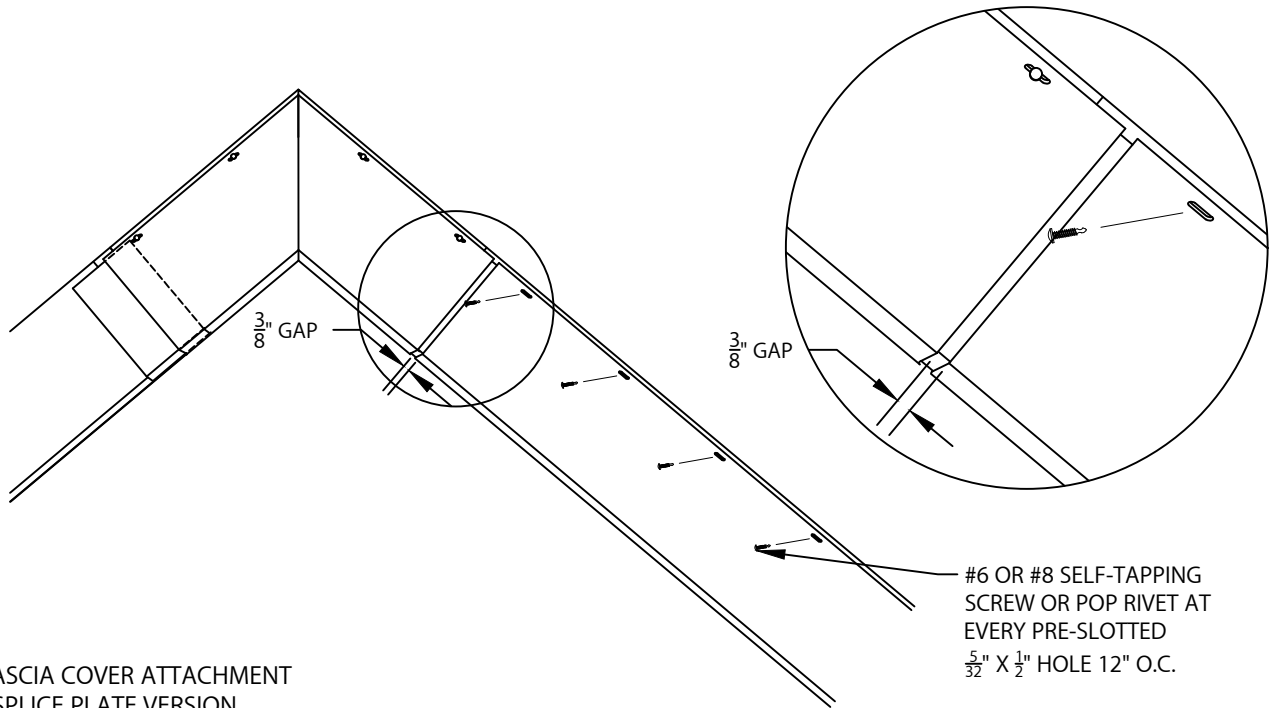

8. FASCIA COVER ATTACHMENT SPLICE PLATE VERSION

HOOK THE BOTTOM OF THE FASCIA COVER UNDER THE DRIP END OF THE BACKER CLEAT. ROTATE THE FASCIA COVER AND FASTEN THE TOP OF THE COVER USING THE PRE-SLOTTED $\frac{5}{32}$ " X $\frac{1}{2}$ " HOLES AT 12" O.C. USING A #6 OR #8 SELF-TAPPING SCREW OR POP RIVET AT EVERY SLOTTED HOLE. LEAVE A $\frac{3}{8}$ " GAP BETWEEN THE FASCIA COVERS TO ALLOW FOR THERMAL EXPANSION.



Phone: 800-558-2162
Fax: 800-770-3934
www.metalera.com

DATE: 09/27/22

SHT.# 7 OF 8

DRN BY: MLM

CKD BY: MM

DWG# 31127-7385

G

HI-PERF RAKE PANEL

WITHOUT VERTICAL "Z" BRACKETS

INSTALLATION INSTRUCTIONS

TYPICAL COMPONENT LIST



24 GA. GALV.
CONTINUOUS BACKER
CLEAT, 12'-0" LENGTHS



FASCIA COVER
12'-0" LENGTHS

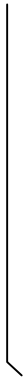

COVER SPLICE PLATE
3 1/2" LENGTHS
(WHEN APPLICABLE)

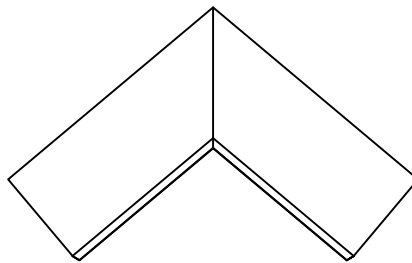

MITER BACKER:
PEAK MITER SHOWN
(WHEN APPLICABLE)

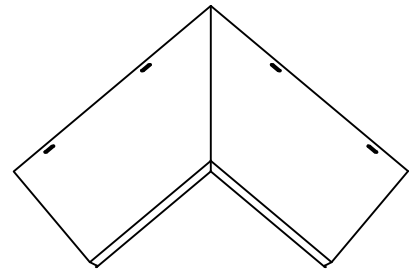

MITER FASCIA COVER:
PEAK MITER SHOWN
(WHEN APPLICABLE)



Phone: 800-558-2162
Fax: 800-770-3934
www.metalera.com

DATE: 09/27/22

SHT.# 8 OF 8

DRN BY: MLM

CKD BY: MM

DWG# 31127-7385

G