



SEAL-TITE GOLD INDUSTRIAL GUTTER

24 GA. / .040" MATERIAL ANSI/SPRI GT-1 TESTED 150 LBS / SQ FT

IGG-1 VERSION

.050" / .063" MATERIAL ANSI/SPRI GT-1 TESTED 210 LBS / SQ FT

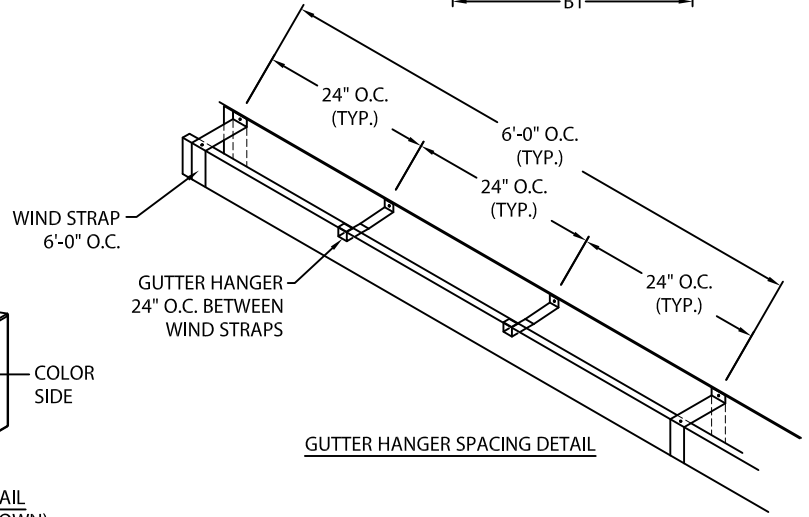
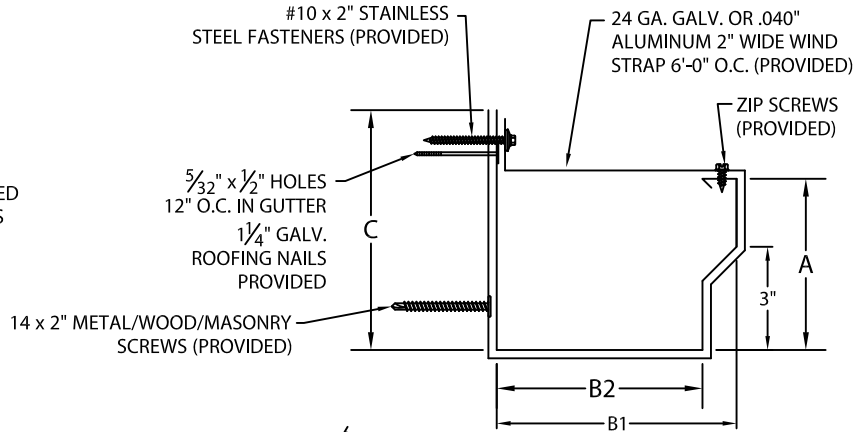
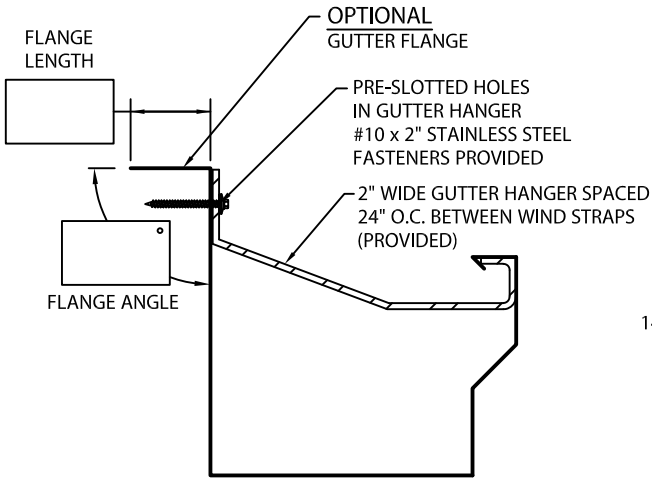

PRODUCT ID #	C	B1	B2	A
<input type="checkbox"/> IGG1-C6	6"	4 3/4"	3 3/4"	4 1/2"
<input type="checkbox"/> IGG1-C7	7"	6"	5"	6"
<input type="checkbox"/> IGG1-C8	8"	7"	6"	7"
<input type="checkbox"/> IGG1-C9	9"	8"	7"	8"

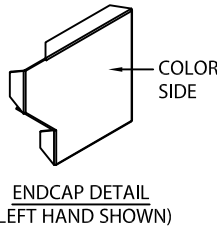

NOTES:

- MAXIMUM DOWNSPOUT DIMENSION NOT TO EXCEED "B2" MINUS 9/16".
- 6" WIDE SPLICE PLATES PROVIDED.
- 1/8" STAINLESS STEEL POP RIVETS PROVIDED.
- UNLESS OTHERWISE NOTED, FABRICATION OF MITERS ARE FURNISHED STANDARD UTILIZING A NON-PENETRATING QUICKLOCK JOINT, THEN FACTORY SEALED WATERTIGHT.
- WELDED ACCESSORIES REQUIRE A MINIMUM MATERIAL THICKNESS OF .050".

MATERIAL:

- ___ 24 GA. GALVANIZED STEEL
- ___ .040" ALUMIINIUM COLOR: _____
- ___ .050" ALUMINUM FINISH: _____
- ___ .063" ALUMINUM
- ___ OTHER _____

QUANTITIES:

- ___ LINEAL FEET 12'-0" LENGTHS
 - ___ OUTSIDE MITERS @ 90°
 - ___ INSIDE MITERS @ 90°
 - ___ RIGHT ENDCAPS
 - ___ LEFT ENDCAPS
 - ___ EXPANSION JOINTS STYLE "1"
 - ___ EXPANSION JOINTS STYLE "2"
- SPECIFY MITER TYPE:
 WELDED
 QUICKLOCK

Fabrication will proceed only after receipt of signed print approval.

Print Approval:

Architect and/or contractor shall verify all dimensions, sizes and quantities. All products to be installed in strict accordance with Metal-Era's printed instructions.

Approved by: _____

Date: _____

FOR NON-90 MITERS SEE PRINT APPROVAL #11012-10010

PROJECT:

ARCHITECT:

ROOFING CONTRACTOR:

REPRESENTATIVE/DISTRIBUTOR:

Corporate Offices, Manufacturing
 1600 Airport Road; Waukesha, WI 53188
 Phone: 800-558-2162
 Fax: 800-373-9156
 www.metalera.com



DATE: 11/02/18

DRN BY: JJC

CKD BY: SAK

SHT.# ___ OF ___

DWG# 11012-26050

D