

SEAL-TITE GOLD INDUSTRIAL GUTTER FOR USE WITH ELIMINAILER®-T

IGG-1 GUTTER, 5.2", 4" FLANGE ELIMINAILER VERSION

FOR USE WITH METAL DECK

U.S. PATENT # 9,878,023 B1

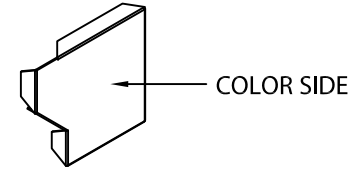
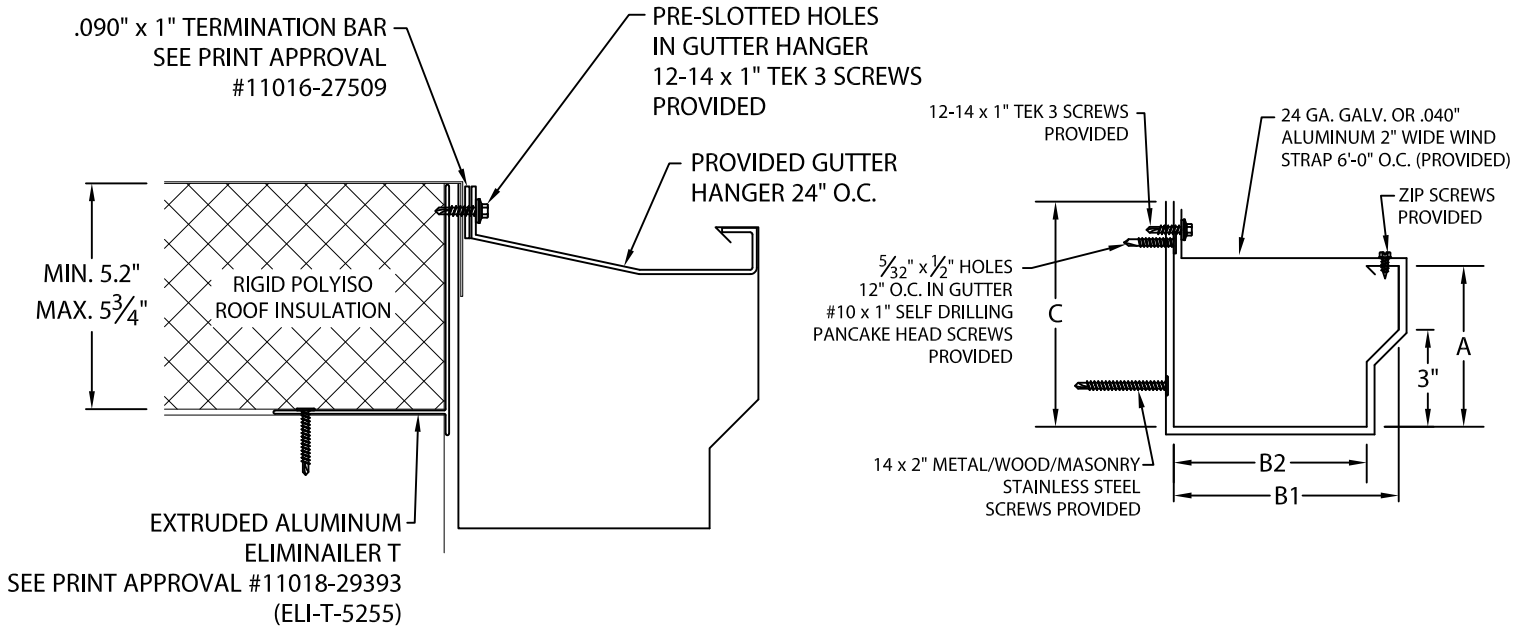

ENDCAP DETAIL
(LEFT HAND SHOWN)

PRODUCT ID #	C	B1	B2	A
<input type="checkbox"/> T-IGG1-C8	8"	7"	6"	7"
<input type="checkbox"/> T-IGG1-C9	9"	8"	7"	8"

NOTES:
 -- MAXIMUM DOWNSPOUT DIMENSION NOT TO EXCEED "B2" MINUS 9/16".
 -- 6" WIDE SPLICE PLATES PROVIDED.
 -- 1/8" STAINLESS STEEL POP RIVETS PROVIDED.
 -- UNLESS OTHERWISE NOTED, FABRICATION OF MITERS ARE FURNISHED STANDARD UTILIZING A NON-PENETRATING QUICKLOCK JOINT, THEN FACTORY SEALED WATERTIGHT.
 -- WELDED ACCESSORIES REQUIRE A MINIMUM MATERIAL THICKNESS OF .050".

MATERIAL:
 ___ 24 GA. GALVANIZED STEEL
 ___ .040" ALUMIINIUM COLOR: _____
 ___ .050" ALUMINUM FINISH: _____
 ___ .063" ALUMINUM
 ___ OTHER _____

Fabrication will proceed only after receipt of signed print approval.
Print Approval:
 Architect and/or contractor shall verify all dimensions, sizes and quantities. All products to be installed in strict accordance with Metal-Era's printed instructions.
 Approved by: _____
 Date: _____

QUANTITIES:
 _____ LINEAL FEET 12'-0" LENGTHS
 _____ OUTSIDE MITERS @ 90°
 _____ INSIDE MITERS @ 90°
 _____ RIGHT ENDCAPS
 _____ LEFT ENDCAPS
 _____ EXPANSION JOINTS STYLE "1"
 _____ EXPANSION JOINTS STYLE "2"
 SPECIFY MITER TYPE:
 WELDED
 QUICKLOCK
 FOR NON-90 MITERS SEE PRINT APPROVAL #11012-10010

PROJECT:	Corporate Offices, Manufacturing
ARCHITECT:	1600 Airport Road; Waukesha, WI 53188
ROOFING CONTRACTOR:	Phone: 800-558-2162
REPRESENTATIVE/DISTRIBUTOR:	Fax: 800-373-9156 www.metalera.com



DATE: 09/08/18	SHT.# _____ OF _____
DRN BY: JJC	
CKD BY: SAK	DWG# 11012-29717 A