



ANCHOR-TITE DRIP EDGE FOR USE WITH ELIMINAILER[®]-T

5.2", 5.5" FLANGE ELIMINAILER VERSION

FOR USE WITH MASONRY WALL

U.S. PATENT # 9,878,023 B1

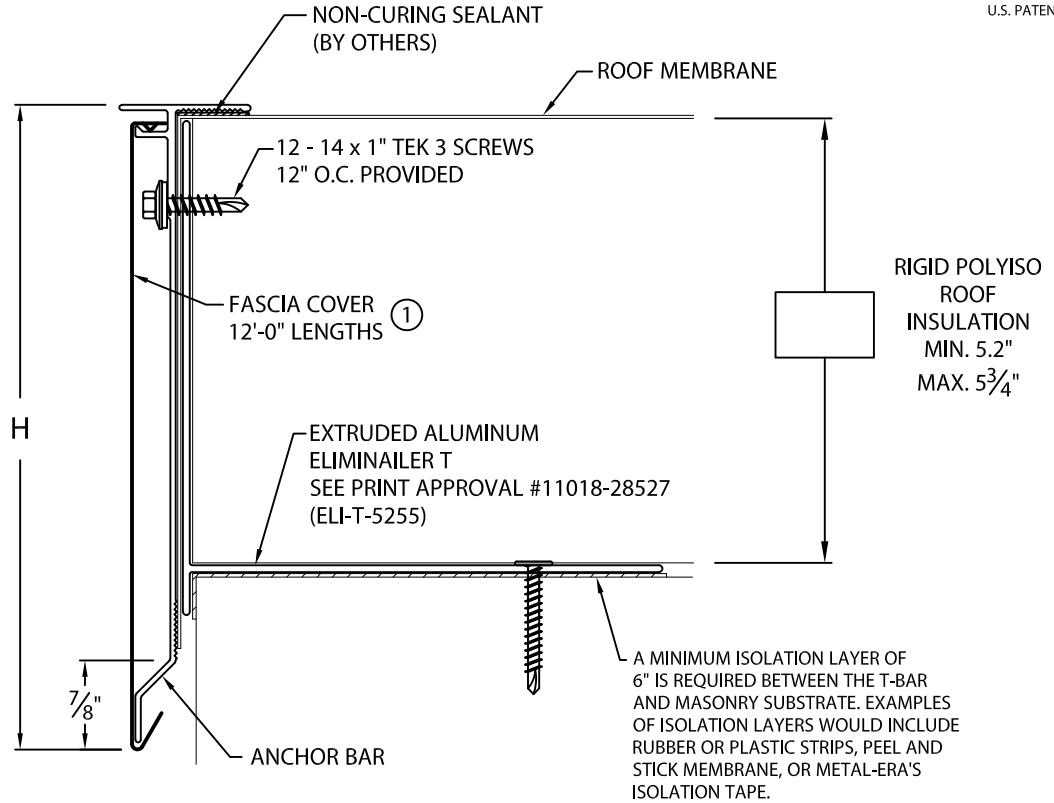

NOTES:

① FASCIA COVER PROVIDED WITH 1" LAP JOINTS.

ANCHOR-TITE DRIP EDGE DIMENSIONS

PRODUCT ID. NO.	H DIM
<input type="checkbox"/> T-AFDE-75	7 1/2"

Fabrication will proceed only after receipt of signed print approval.

Print Approval:

Architect and/or contractor shall verify all dimensions, sizes and quantities. All products to be installed in strict accordance with Metal-Era's printed instructions.

Approved by: _____

Date: _____

DRIP EDGE COVER MATERIAL:

___ 24 GA. GALVANIZED STEEL

___ .040" ALUMINUM

___ OTHER _____

COLOR: _____

FINISH: _____

QUANTITIES:

_____ LINEAL FEET 12'-0" LENGTHS

_____ OUTSIDE MITER(S) @ 90°

_____ INSIDE MITER(S) @ 90°

FOR NON-90 MITERS SEE PRINT APPROVAL #11010-1103

PROJECT:

ARCHITECT:

ROOFING CONTRACTOR:

REPRESENTATIVE/DISTRIBUTOR:

Corporate Offices, Manufacturing
1600 Airport Road; Waukesha, WI 53188
Phone: 800-558-2162
Fax: 800-373-9156
www.metalera.com



DATE: 08/29/18

DRN BY: JJC

CKD BY: SAK

SHT.# ___ OF ___

DWG# 11010-28990

B

ELIMINAILER®-T

FOR USE WITH MASONRY WALL, 5.2", 5.5" FLANGE VERSION

U.S. PATENT # 9,878,023 B1

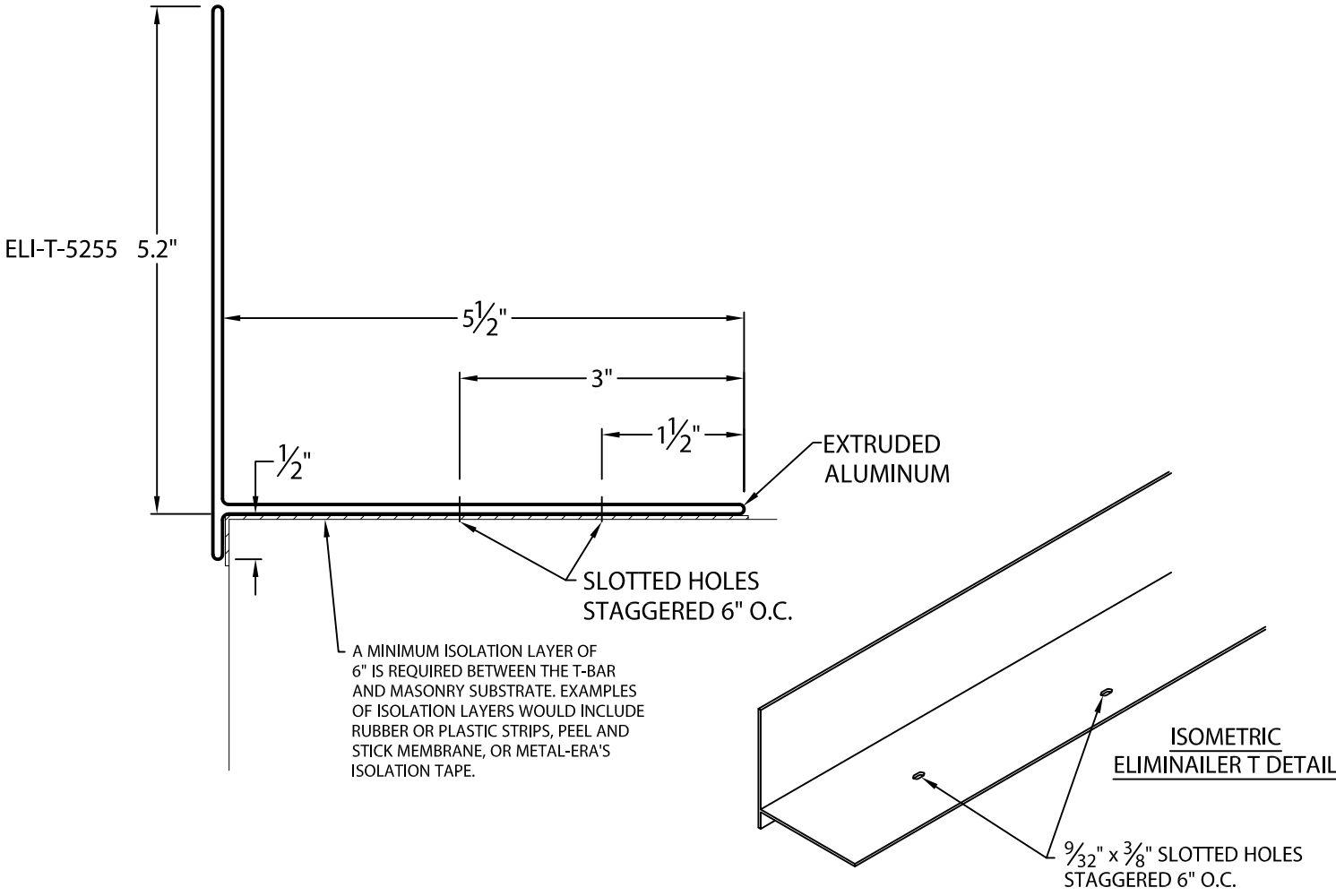

Fabrication will proceed only after receipt of signed print approval.

Print Approval:

Architect and/or contractor shall verify all dimensions, sizes and quantities. All products to be installed in strict accordance with Metal-Era's printed instructions.

Approved by: _____
Date: _____

PLEASE INDICATE SUBSTRATE (IF SUBSTRATE INFORMATION IS NOT GIVEN, CONCRETE WALL FASTENERS WILL BE PROVIDED)

- CONCRETE WALL (3000 PSI CONCRETE):
#14 x 1 1/4" FASTENERS PROVIDED
- CMU WALL (1500 PSI):
1/4" x 1 1/2" SPIKE FASTENERS PROVIDED

QUANTITIES:

_____ LINEAL FEET 12'-0" LENGTHS
_____ ROLLS ISOLATION TAPE 6" WIDE (180 FT PER ROLL)

PROJECT: _____
ARCHITECT: _____
ROOFING CONTRACTOR: _____
REPRESENTATIVE/DISTRIBUTOR: _____

Corporate Offices, Manufacturing
1600 Airport Road; Waukesha, WI 53188
Phone: 800-558-2162
Fax: 800-373-9156
www.metalera.com



DATE: 08/29/18
DRN BY: JJC
CKD BY: SAK

SHT.# ____ OF ____
DWG# 11018-28527

B