



# SEAL-TITE GOLD INDUSTRIAL GUTTER

24 GA. / .040" MATERIAL ANSI/SPRI GT-1 TESTED 150 LBS / SQ FT

IGG-2 VERSION

.050" / .063" MATERIAL ANSI/SPRI GT-1 TESTED 210 LBS / SQ FT

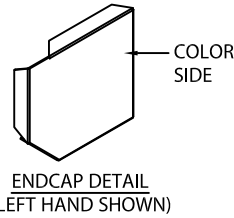
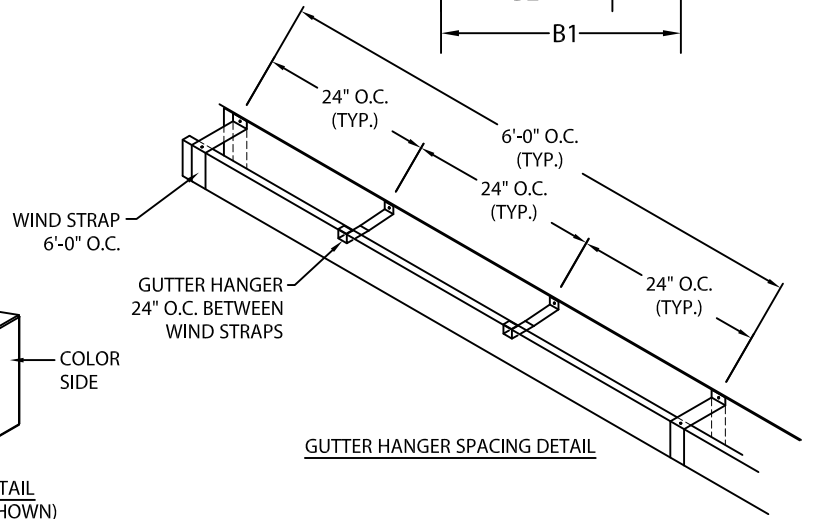
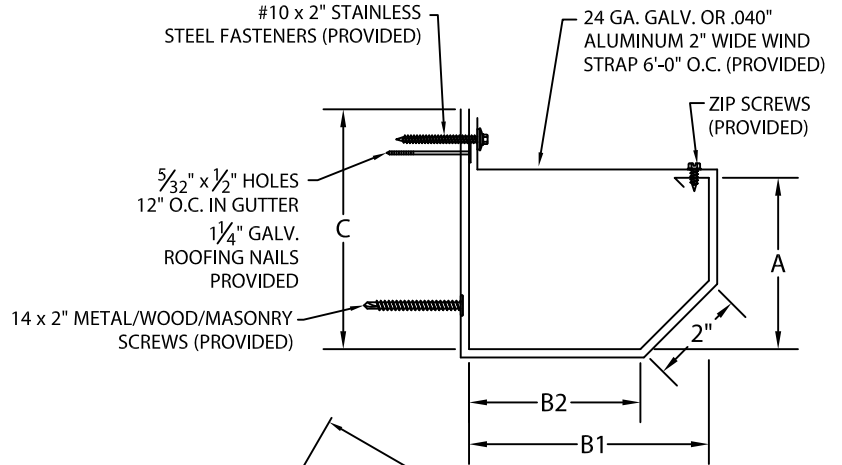
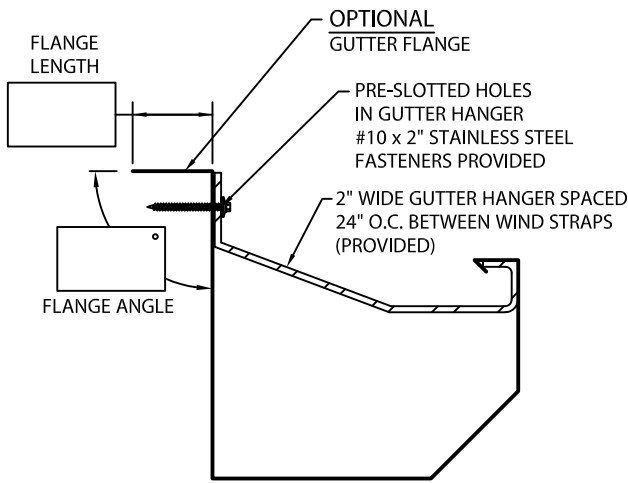

PRODUCT ID #	C	B1	B2	A
<input type="checkbox"/> IGG2-C6	6"	5"	3 9/16"	4 1/2"
<input type="checkbox"/> IGG2-C7	7"	6"	4 9/16"	6"
<input type="checkbox"/> IGG2-C8	8"	7"	5 9/16"	7"
<input type="checkbox"/> IGG2-C9	9"	8"	6 9/16"	8"

**NOTES:**

- MAXIMUM DOWNSPOUT DIMENSION NOT TO EXCEED "B2" MINUS 9/16".
- 6" WIDE SPLICE PLATES PROVIDED.
- 1/8" STAINLESS STEEL POP RIVETS PROVIDED.
- UNLESS OTHERWISE NOTED, FABRICATION OF MITERS ARE FURNISHED STANDARD UTILIZING A NON-PENETRATING QUICKLOCK JOINT, THEN FACTORY SEALED WATERTIGHT.
- WELDED ACCESSORIES REQUIRE A MINIMUM MATERIAL THICKNESS OF .050".

Fabrication will proceed only after receipt of signed print approval.

**Print Approval:**

Architect and/or contractor shall verify all dimensions, sizes and quantities. All products to be installed in strict accordance with Metal-Era's printed instructions.

Approved by: \_\_\_\_\_

Date: \_\_\_\_\_

**MATERIAL:**

- \_\_\_ 24 GA. GALVANIZED STEEL
- \_\_\_ .040" ALUMIINIUM COLOR: \_\_\_\_\_
- \_\_\_ .050" ALUMINIUM FINISH: \_\_\_\_\_
- \_\_\_ .063" ALUMINIUM
- \_\_\_ OTHER \_\_\_\_\_

**QUANTITIES:**

- \_\_\_ LINEAL FEET 12'-0" LENGTHS
  - \_\_\_ OUTSIDE MITERS @ 90°
  - \_\_\_ INSIDE MITERS @ 90°
  - \_\_\_ RIGHT ENDCAPS
  - \_\_\_ LEFT ENDCAPS
  - \_\_\_ EXPANSION JOINTS STYLE "1"
  - \_\_\_ EXPANSION JOINTS STYLE "2"
- SPECIFY MITER TYPE:  
 WELDED  
 QUICKLOCK

FOR NON-90 MITERS SEE PRINT APPROVAL #11012-10010

PROJECT:

ARCHITECT:

ROOFING CONTRACTOR:

REPRESENTATIVE/DISTRIBUTOR:

Corporate Offices, Manufacturing  
 1600 Airport Road; Waukesha, WI 53188  
 Phone: 800-558-2162  
 Fax: 800-373-9156  
 www.metalera.com



DATE: 11/02/18

DRN BY: JJC

CKD BY: SAK

SHT.# \_\_\_ OF \_\_\_

DWG# 11012-23792

D