

PERMA-TITE EXPANSION JOINT

ROOF TO ROOF VERSION

INSTALLATION INSTRUCTIONS

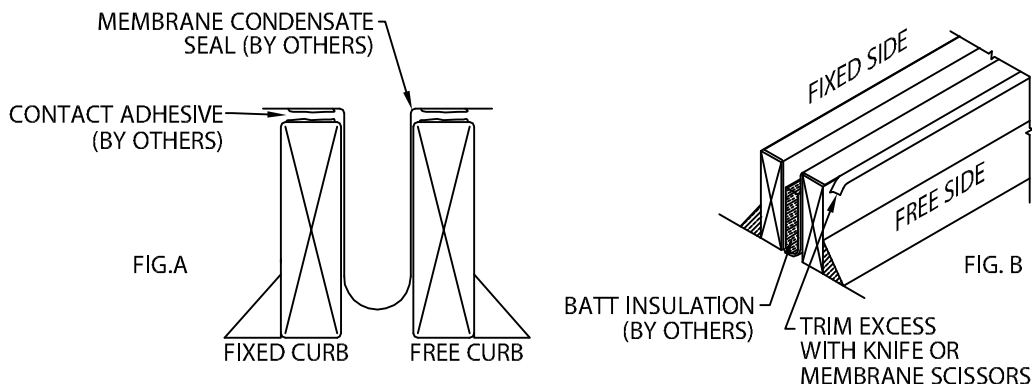

1. Condensation Seal

Begin the expansion joint installation by first inserting the condensation seal (by others) into the expansion joint gap between the curbs, extending the pocket to a depth at least equal to the width of the expansion joint, more if allowable. Lap 6" and seal all membrane joints. Fold in the ends of the membrane seal and secure to the wood curb with contact adhesive (by others), applying to curb and membrane condensate seal, to temporarily hold the membrane in place (Fig. A). Trim membrane to be even with the outside edges of the curbs, if necessary (Fig. B). Insert the fiberglass insulation (by others) with the system into the pocket of the membrane.

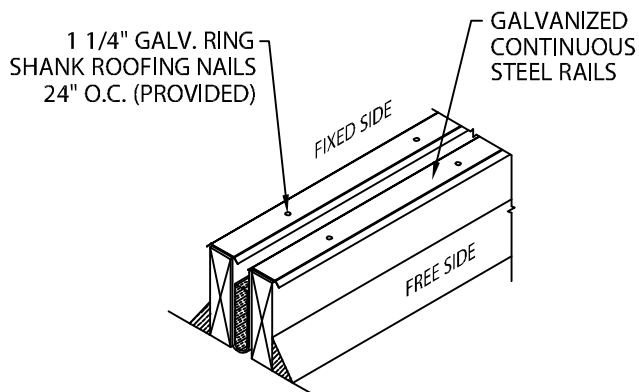

2. Continuous Rails

Position the galvanized steel rails on top of the wood curbs. Fasten steel rails to the top of the wood curbs at 24" O.C. with provided 1 1/4" galvanized ring shank roofing nails.

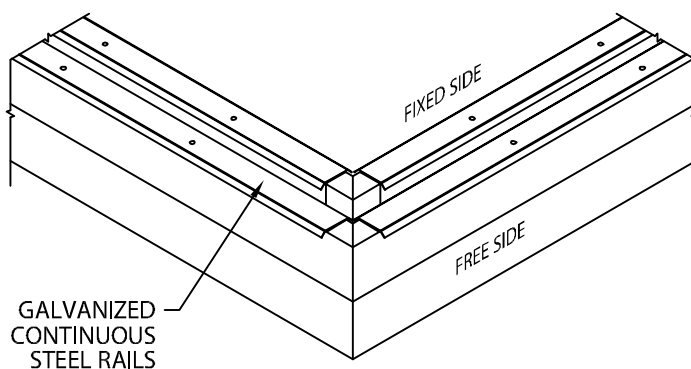

3. Miters

Field cut curbs at a 90° angle as shown. Follow steps 1 and 2, installing condensation seal, batt insulation and continuous rails.

PERMA-TITE EXPANSION JOINT

ROOF TO ROOF VERSION

INSTALLATION INSTRUCTIONS

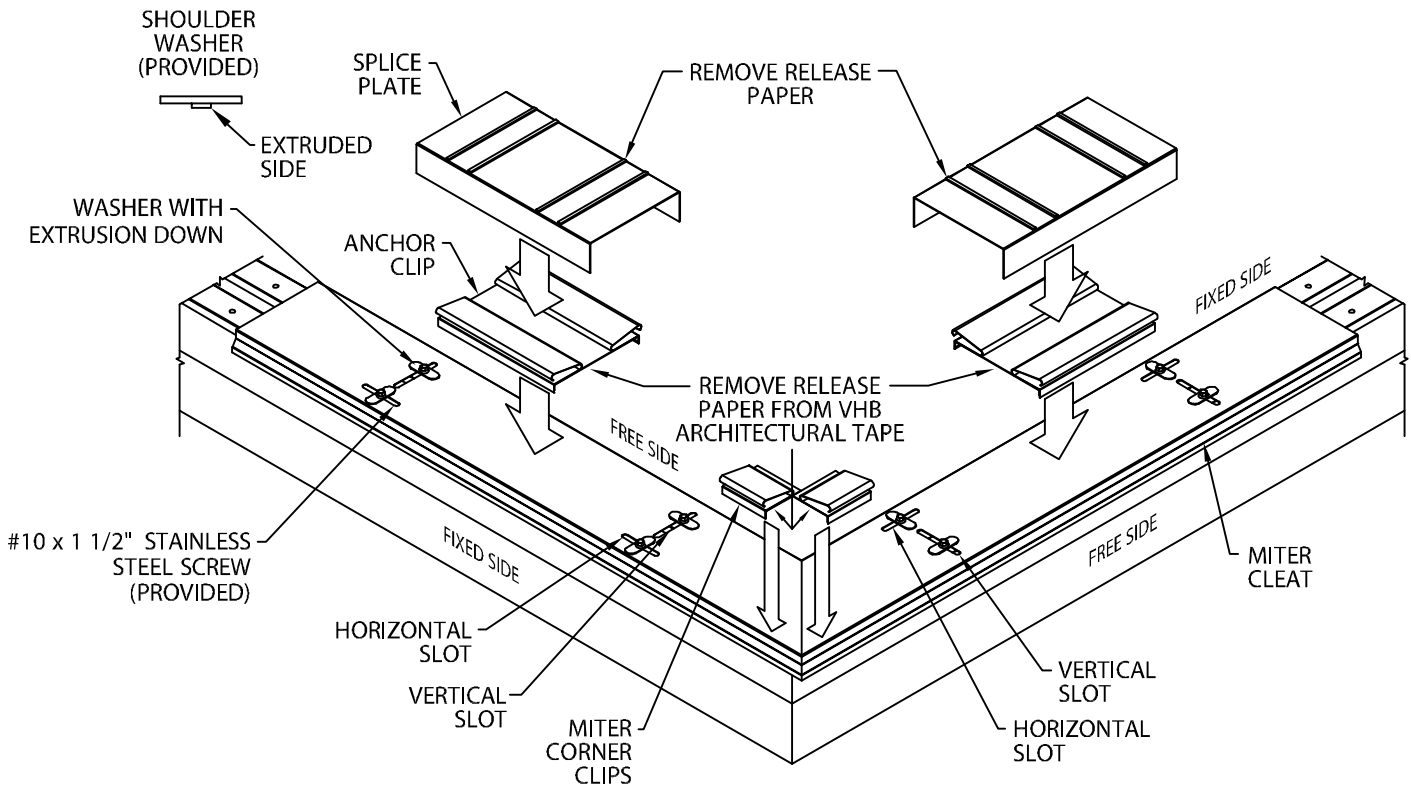

4. Miters

Lay the miter cleat in place over the expansion joint curbs. Place the miter cleat so slots are centered on curbs. The cleat overhangs curbs noted as free side, which is also the same side as the vertical slots. Secure the continuous cleat with #10 x 1 1/2" stainless steel fasteners and shouldered washers provided with the system. The washers are to be placed extruded side down in approximately the center of the horizontal slots and approximately in the center of the curb for the vertical slots. Remove release paper from VHB architectural tape located on bottom of anchor clips and miter corner clips. Place galvanized miter corner clips on cleat as shown. Center 8" wide anchor clips between slots. Center 12" splice plate onto anchor clips as shown. Remove release paper from top of factory applied sealant strips.

DO NOT OVERDRIVE THE SCREWS INTO THE CLEAT SO THAT THE SCREWS DO NOT RESTRICT MOVEMENT.

PERMA-TITE EXPANSION JOINT

ROOF TO ROOF VERSION

INSTALLATION INSTRUCTIONS

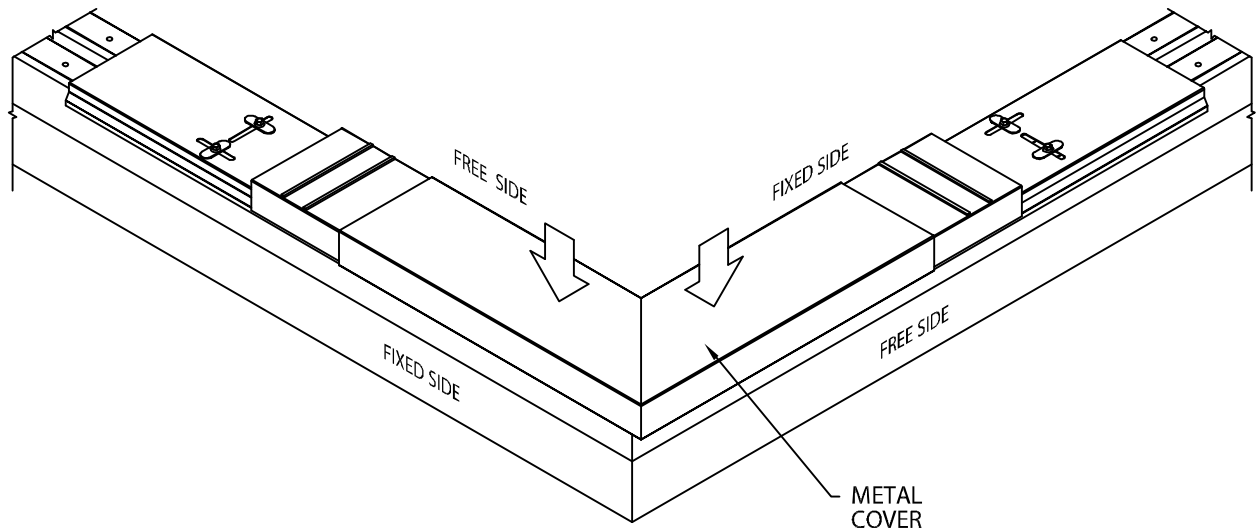

5. Miters

Press miter cover straight down into place. Continue downward pressure until snap lock occurs on both legs.

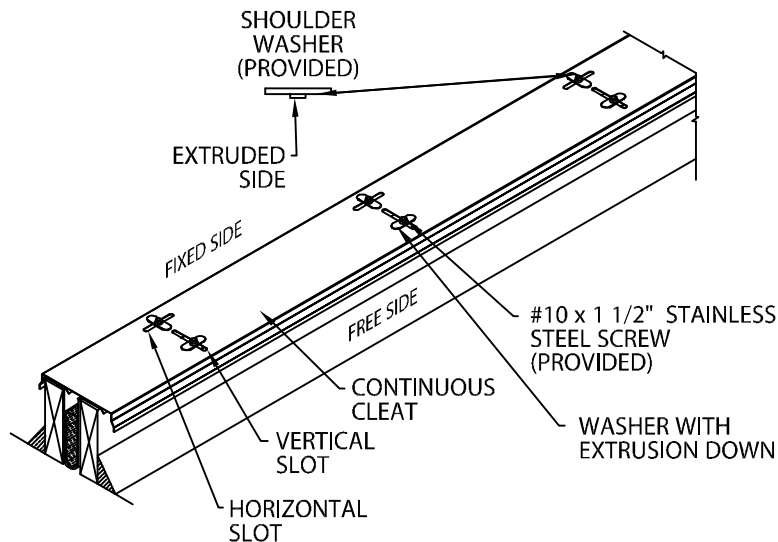

6. Endcaps

Place continuous cleat over the expansion joint curbs. If this step was preceded by installing a miter, the slots must face the same direction as the miter cleat on those curbs. The cleat should extend beyond the free side of the expansion joint with slots centered on curbs. Secure the continuous cleat with #10 x 1 1/2" stainless steel fasteners and shouldered washers provided with the system. The washers are to be placed extruded side down in approximately the center of the horizontal slots and approximately in the center of the curb for the vertical slots.

DO NOT OVERDRIVE THE SCREWS INTO THE CLEAT SO THAT THE SCREWS DO NOT RESTRICT MOVEMENT.

PERMA-TITE EXPANSION JOINT

ROOF TO ROOF VERSION

INSTALLATION INSTRUCTIONS

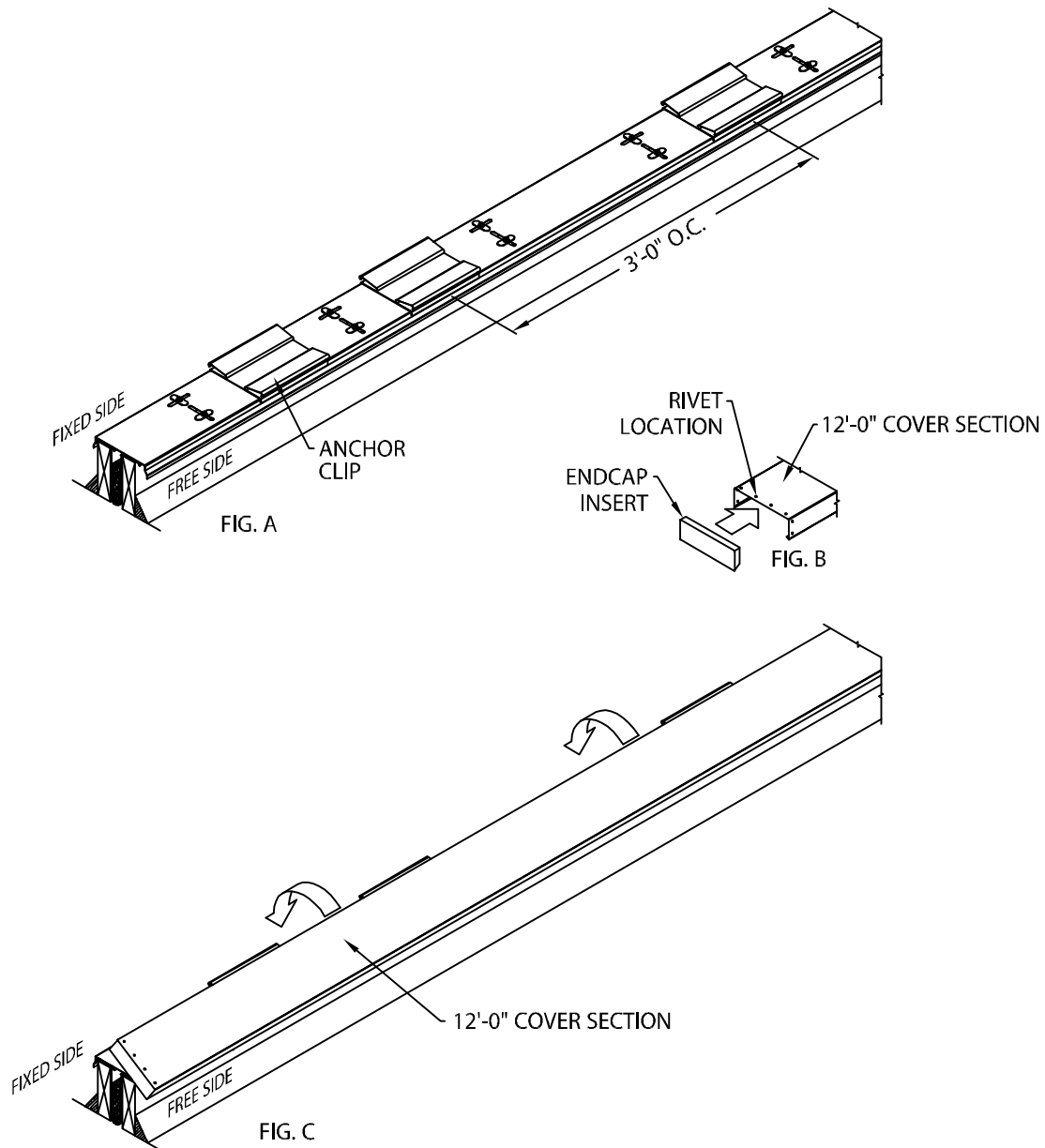

7. Endcap Inserts

Remove release paper from VHB architectural tape located on bottom of anchor clips. Center 8" wide anchor clips between first and second set of slots (Fig. A) Place additional anchor clips 3'-0" O.C., placing a splice plate onto anchor clip at splice joint. Place endcap insert into 12'-0" cover section (Fig. B). Pop rivet (not provided) insert into place and seal tight using non-curing sealant (not provided) on inside along seams. Hook endcap section on the free side of the continuous cleat and rotate into place (Fig. C). Engage rear leg onto continuous cleat by pressing downward until snap lock occurs.

PERMA-TITE EXPANSION JOINT

ROOF TO ROOF VERSION

INSTALLATION INSTRUCTIONS

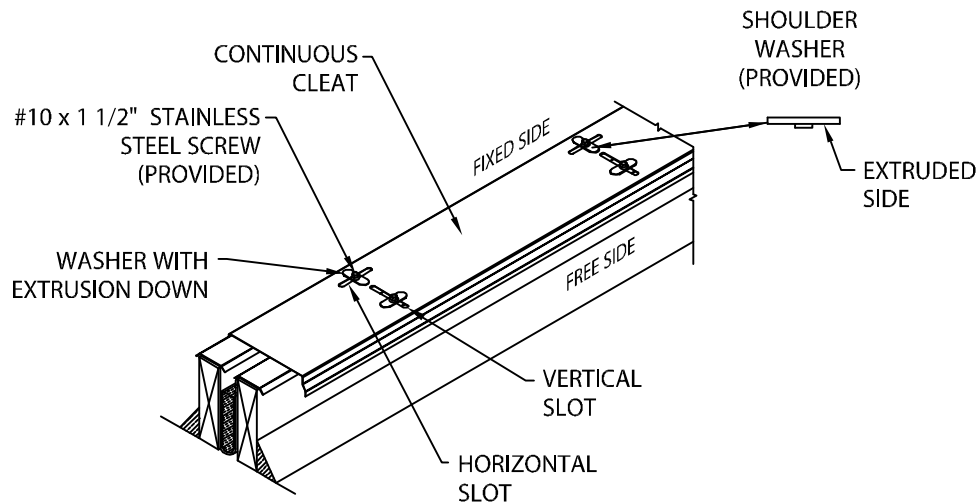

8. Continuous Cleat

Place continuous cleat over the expansion joint curbs. If this step was preceded by installing a miter, the slots must face the same direction as the miter cleat on those curbs. The cleat should extend beyond the free side of the expansion joint. Secure the continuous cleat with #10 x 1 1/2" stainless steel fasteners and shouldered washers provided with the system. The washers are to be placed extruded side down in approximately the center of the horizontal slots and approximately in the center of the curb for the vertical slots.

DO NOT OVERDRIVE THE SCREWS INTO THE CLEAT SO THAT THE SCREWS DO NOT RESTRICT MOVEMENT.

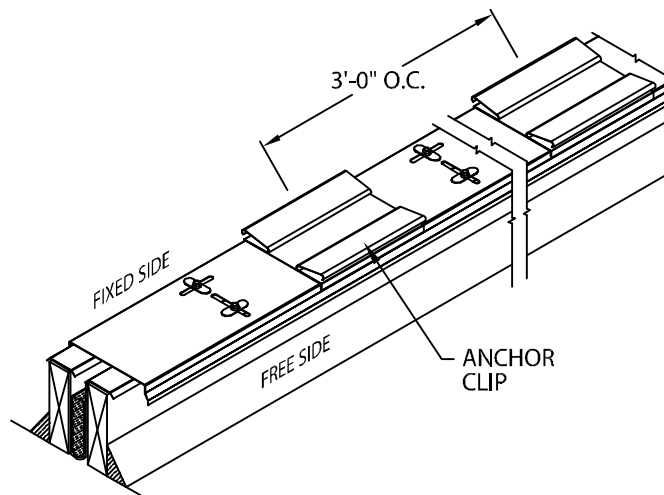

9. Anchor Clips

Remove release paper from VHB architectural tape located on bottom of anchor clips. Center 8" wide anchor clip between slots as shown. Continue placing anchor clips 3'-0" O.C.

PERMA-TITE EXPANSION JOINT

ROOF TO ROOF VERSION

INSTALLATION INSTRUCTIONS

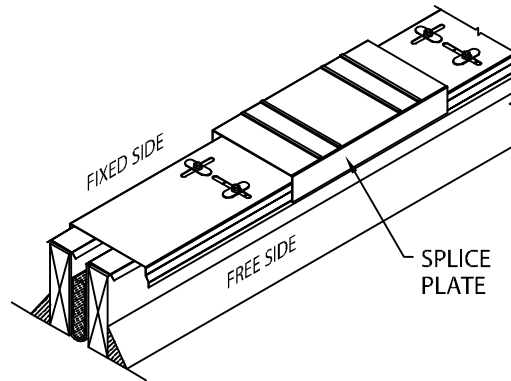

10. Splice Plates

Center splice plate onto anchor clips at splice joints, 12'-0" O.C.

NOTE: Remove release paper from sealant strips.

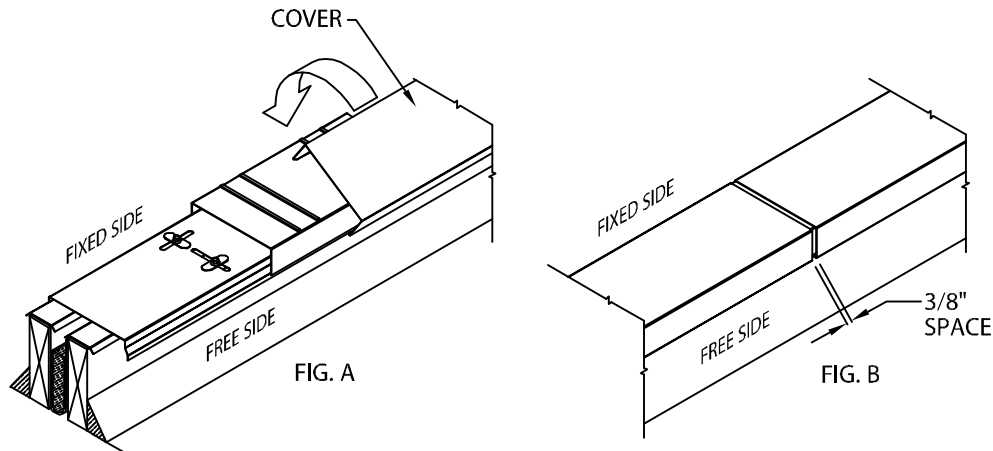

11. Expansion Joint Cover

Install the cover sections onto the continuous cleats. Hook cover section on the free side of the continuous cleat and rotate into place (Fig. A). Engage rear leg onto continuous cleat by pressing downward until snap lock occurs. Continue installing cover with a 3/8" space at splice joints to allow for thermal expansion (Fig. B). Field cut where necessary using a fine tooth hacksaw or snips.

NOTE: Remove protective film immediately.

PERMA-TITE EXPANSION JOINT

ROOF TO ROOF VERSION

INSTALLATION INSTRUCTIONS

TYPICAL INSTALLATION

