

HI-PERF RIDGE VENT

SLOPED ROOF MEETS VERTICAL WALL, SHINGLED VERSION

INSTALLATION INSTRUCTIONS

U.S. PATENT # 7,823,343 B1

DETAIL A

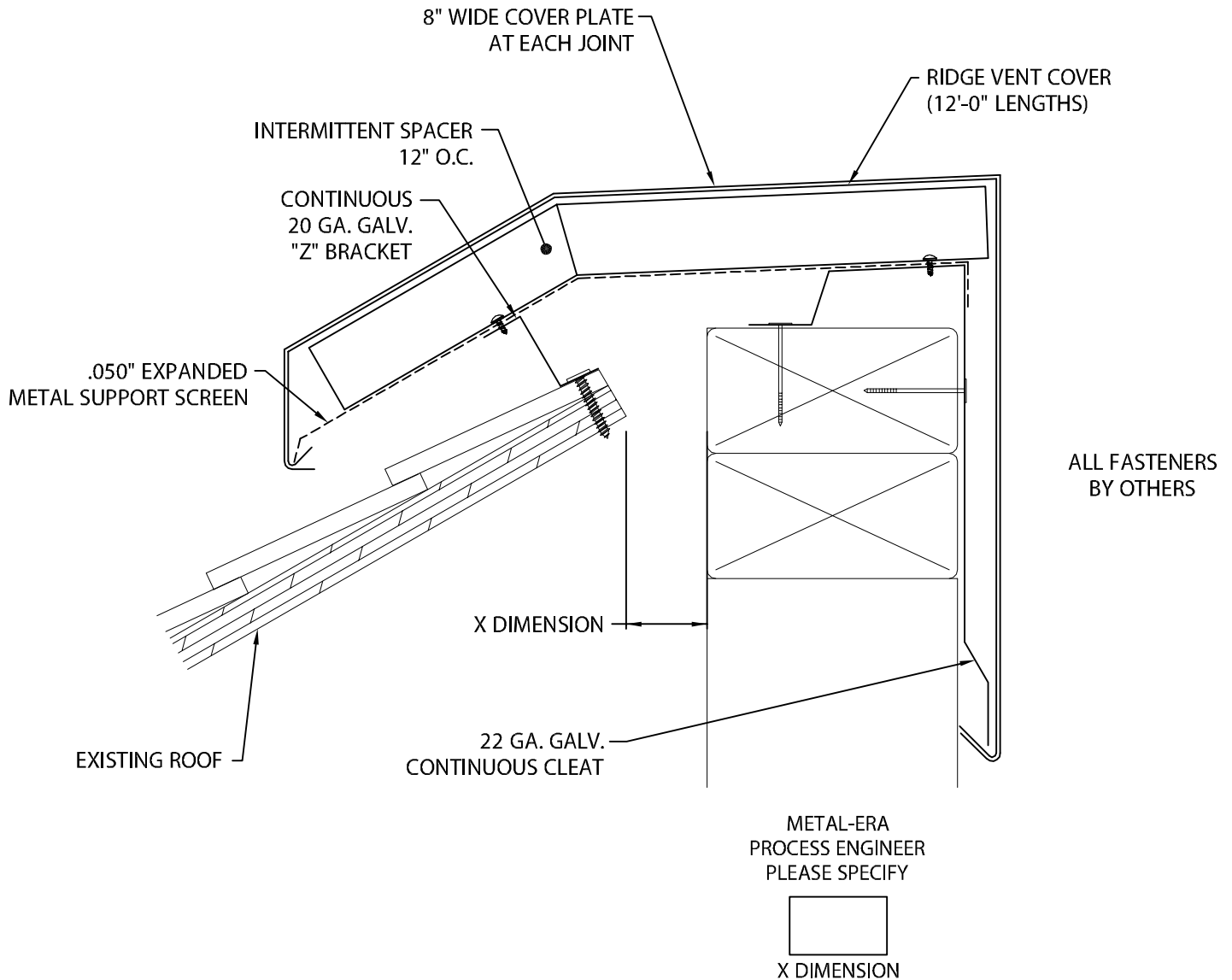

CAUTION! INSTALLERS SHALL WEAR PROTECTIVE EYE WEAR TO PREVENT INJURY. DO NOT OVERDRIVE FASTENERS, AS STRIPPING CAN OCCUR AT HIGH DRIVER TORQUE. RECOMMENDED DRIVING TOOL: 600 - 800 rpm ELECTRIC DRILL EQUIPPED WITH DEPTH-SENSING NOSE-PIECE TO PREVENT DRIVING AND STRIPOUT. DO NOT USE IMPACT TYPE TOOL.

IMPORTANT! BE SURE TO REMOVE PROTECTIVE PLASTIC FILM PRIOR TO INSTALLING EACH COVER SECTION.

NOTE: ALL FASTENERS MUST MEET MINIMUM 240 LB. PULL-OUT FOR SUBSTRATE.



Phone: 800-558-2162
Fax: 800-770-3934
www.metalera.com

DATE: 03/09/16

SHT.# 1 OF 4

DRN BY: JJC

CKD BY: SAK

DWG# 31124-15001

E

HI-PERF RIDGE VENT

SLOPED ROOF MEETS VERTICAL WALL, SHINGLED VERSION

INSTALLATION INSTRUCTIONS

U.S. PATENT # 7,823,343 B1

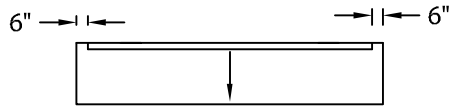
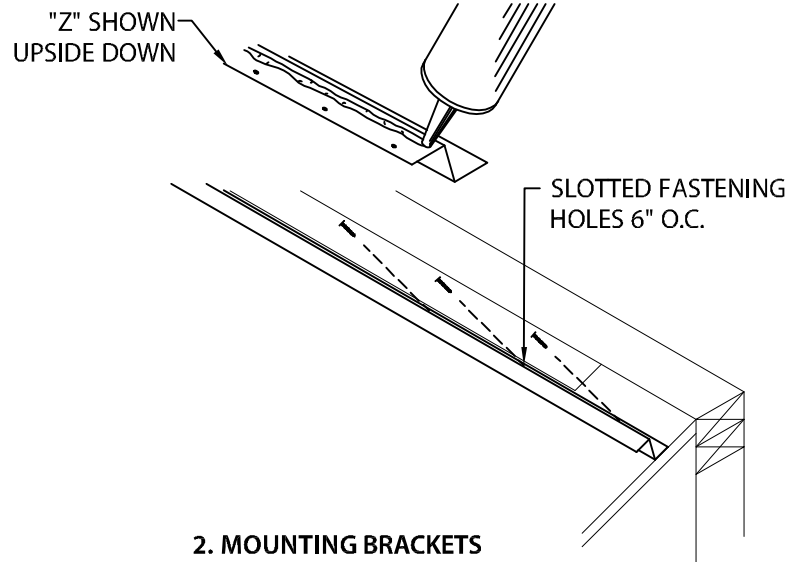

1. PREPARE RIDGE

CUT OPENING AT RIDGE "X" DIMENSION. (SEE DETAIL "A".)

2. MOUNTING BRACKETS

TO PREVENT MOISTURE ENTRY UNDER THE "Z", APPLY A GENEROUS BEAD OF NON-CURING SEALANT TO BOTTOM OF FLANGE. FASTEN BRACKETS TO ROOF AT 6" O.C. WITH APPROPRIATE FASTENERS USING PRE-PUNCHED SLOTTED HOLES. LAP "Z'S" 1".

NOTE: FOAM/SEALANT SHOULD BE PLACED BETWEEN THE "Z" AND VERTICAL WALL OVER THE OSB ON THE LAST 6" AT BOTH ENDS (SEE STEP 1)

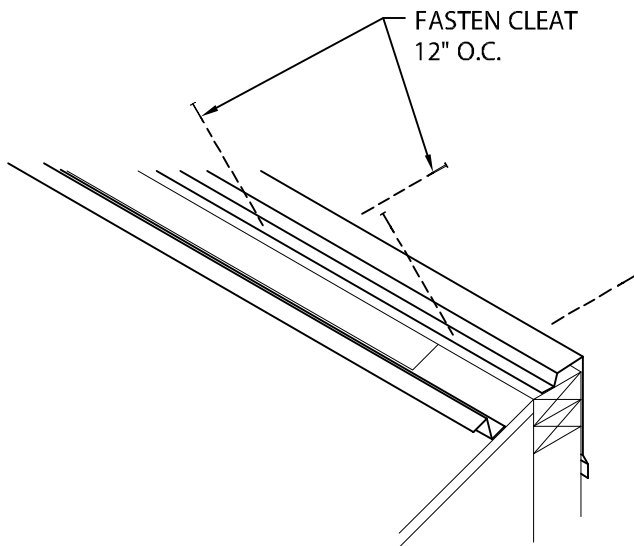

3. CONTINUOUS CLEAT

FASTEN CONTINUOUS CLEAT TO WALL IN FACE AND TOP FLANGE 12" O.C. AS SHOWN USING APPROPRIATE FASTENERS FOR SUBSTRATE.

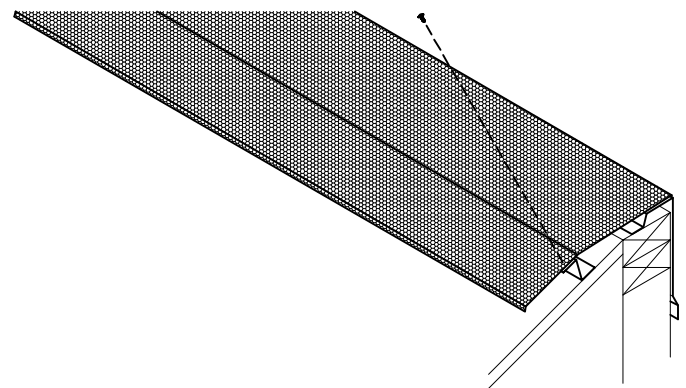

4. EXPANDED METAL SUPPORT SCREEN

PLACE SCREEN OVER "Z" BRACKETS. TEMPORARILY FASTEN TO "Z" BRACKETS AT EACH END OF 12'-0" LENGTH TO HOLD IN PLACE.



Phone: 800-558-2162
Fax: 800-770-3934
www.metalera.com

DATE: 03/09/16

SHT.# 2 OF 4

DRN BY: JJC

CKD BY: SAK

DWG# 31124-15001

E

HI-PERF RIDGE VENT

SLOPED ROOF MEETS VERTICAL WALL, SHINGLED VERSION

INSTALLATION INSTRUCTIONS

5. INTERMITTENT SPACERS

STARTING AT THE END OF THE ROOF WHERE THE ENDCAPS WILL BE PLACED, FASTEN INTERMITTENT SPACERS THRU SCREEN INTO "Z" BRACKET AND CONTINUOUS CLEAT. THE FIRST SPACER SHOULD BE 4" O.C. FROM THE END OF WALL. THE SECOND SPACER IS 8" O.C. FROM THE FIRST SPACER. CONTINUE INSTALLING SPACERS AT 12" O.C. AS SHOWN. USE APPROPRIATE FASTENERS. THE REASON FOR THE SECOND SPACER IS THAT IT IS ADVANTAGEOUS TO HAVE A SPACER AT THE JOINTS. IT IS RECOMMENDED THAT THIS PRACTICE CONTINUES THROUGHOUT THE INSTALLATION. IMPORTANT: THE BENDS ON TOP OF THE SPACER MUST ALL BE FACING AWAY FROM THE END OF THE ROOF.

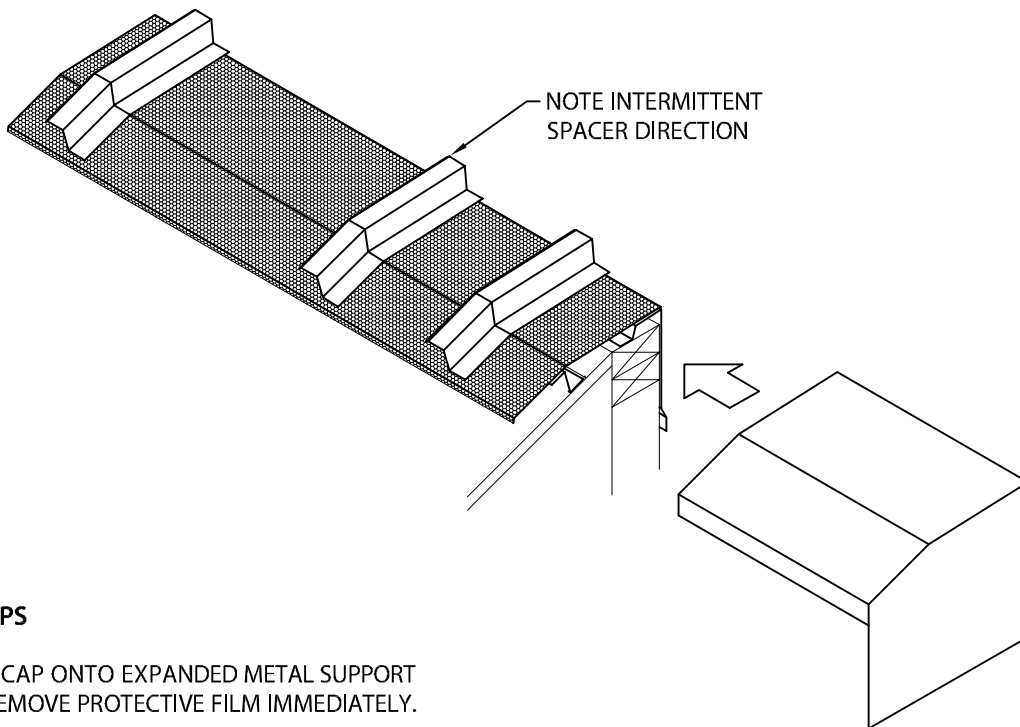
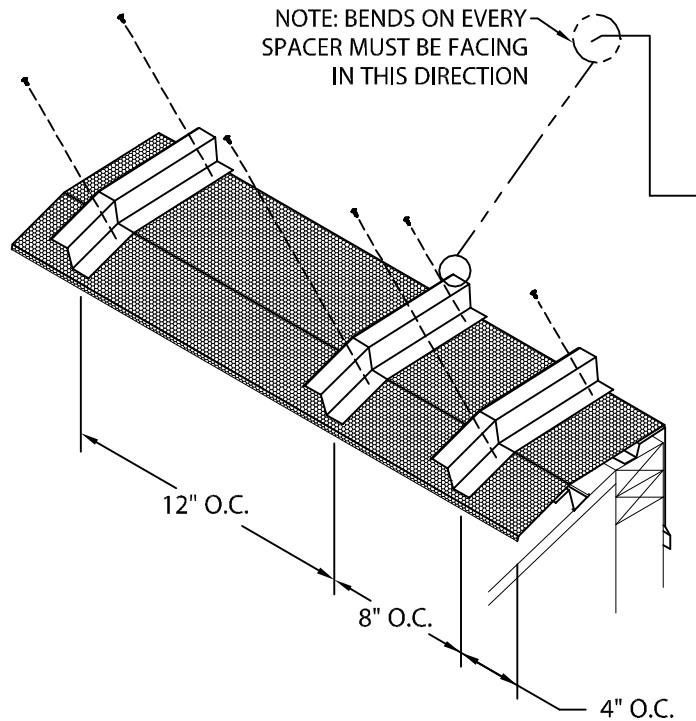

6. ENDCAPS

SLIDE ENDCAP ONTO EXPANDED METAL SUPPORT SCREEN. REMOVE PROTECTIVE FILM IMMEDIATELY.



Phone: 800-558-2162
Fax: 800-770-3934
www.metalera.com

DATE: 03/09/16

SHT.# 3 OF 4

DRN BY: JJC

CKD BY: SAK

DWG# 31124-15001

E

HI-PERF RIDGE VENT

SLOPED ROOF MEETS VERTICAL WALL, SHINGLED VERSION

INSTALLATION INSTRUCTIONS

U.S. PATENT # 7,823,343 B1

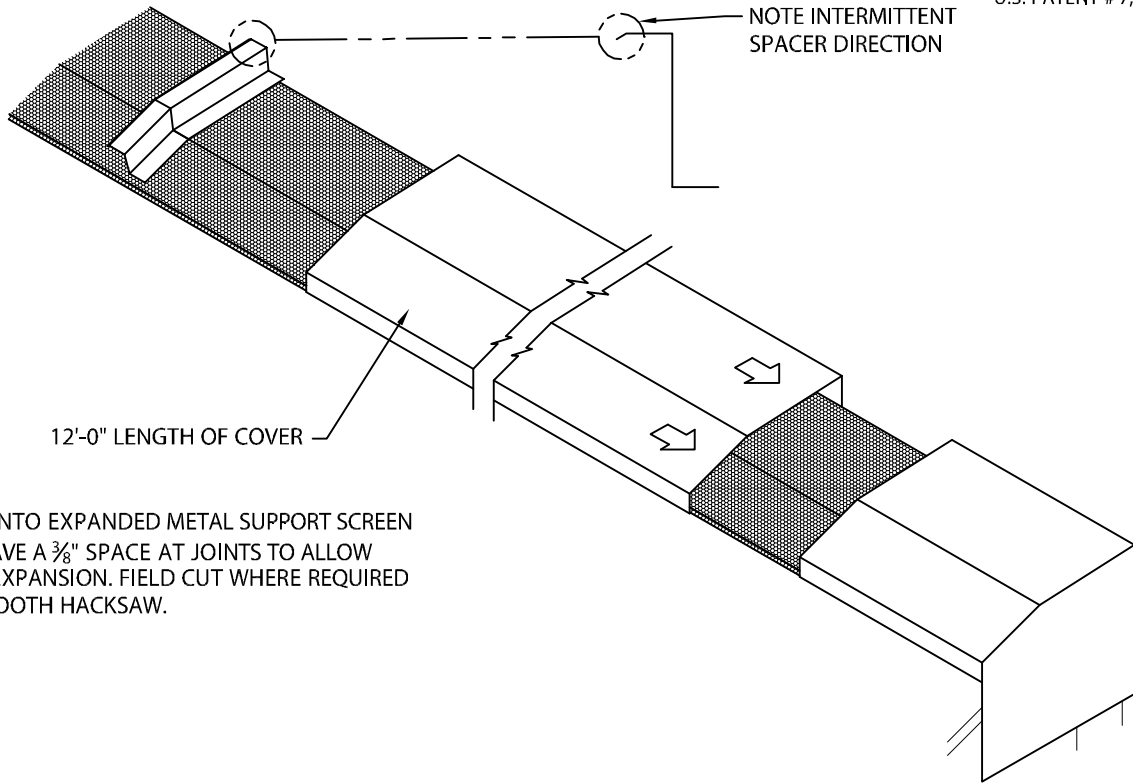

7. COVER

12'-0" LENGTH OF COVER

SLIDE COVER ONTO EXPANDED METAL SUPPORT SCREEN AS SHOWN. LEAVE A $\frac{3}{8}$ " SPACE AT JOINTS TO ALLOW FOR THERMAL EXPANSION. FIELD CUT WHERE REQUIRED USING A FINE TOOTH HACKSAW.

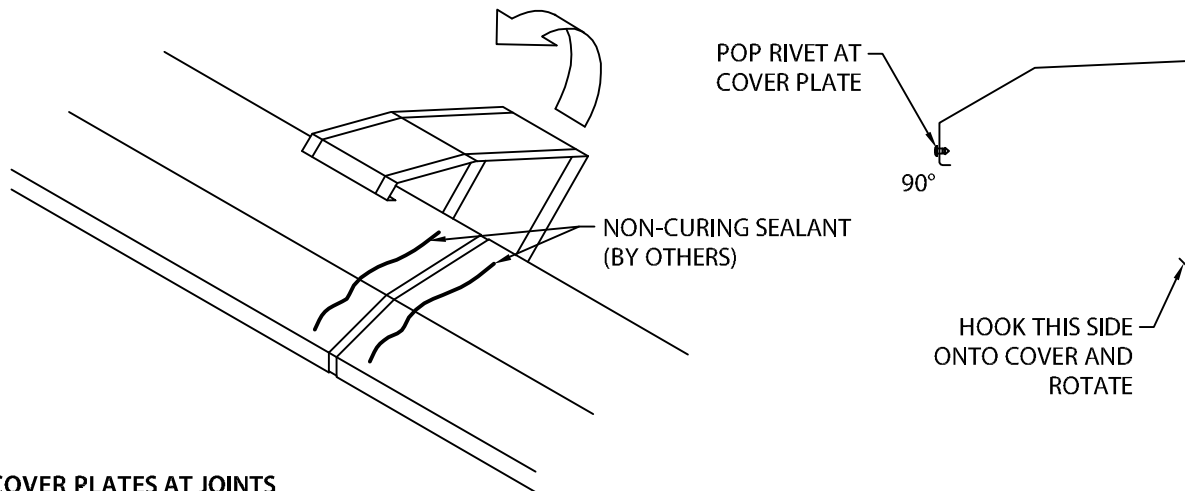

8. COVER PLATES AT JOINTS

APPLY A GENEROUS BEAD OF NON-CURING SEALANT (BY OTHERS) TO EACH SIDE OF JOINT. HOOK COVER PLATE ONTO COVER AT JOINTS AND ROTATE INTO PLACE. POP RIVET INTO COVER PLATE AT ONE SIDE OF THE JOINT (FASTEN SIDE WHICH HAS 90° DRIP ANGLE). THIS WILL PREVENT MIGRATION.



Phone: 800-558-2162
Fax: 800-770-3934
www.metalera.com

DATE: 03/09/16

SHT.# 4 OF 4

DRN BY: JJC

CKD BY: SAK

DWG# 31124-15001

E