

# SEAL-TITE GOLD INDUSTRIAL GUTTER FOR USE WITH ELIMINAILER®-T

IGG-1 GUTTER, 5.2", 4" FLANGE ELIMINAILER VERSION

FOR USE WITH MASONRY WALL

U.S. PATENT # 9,878,023 B1

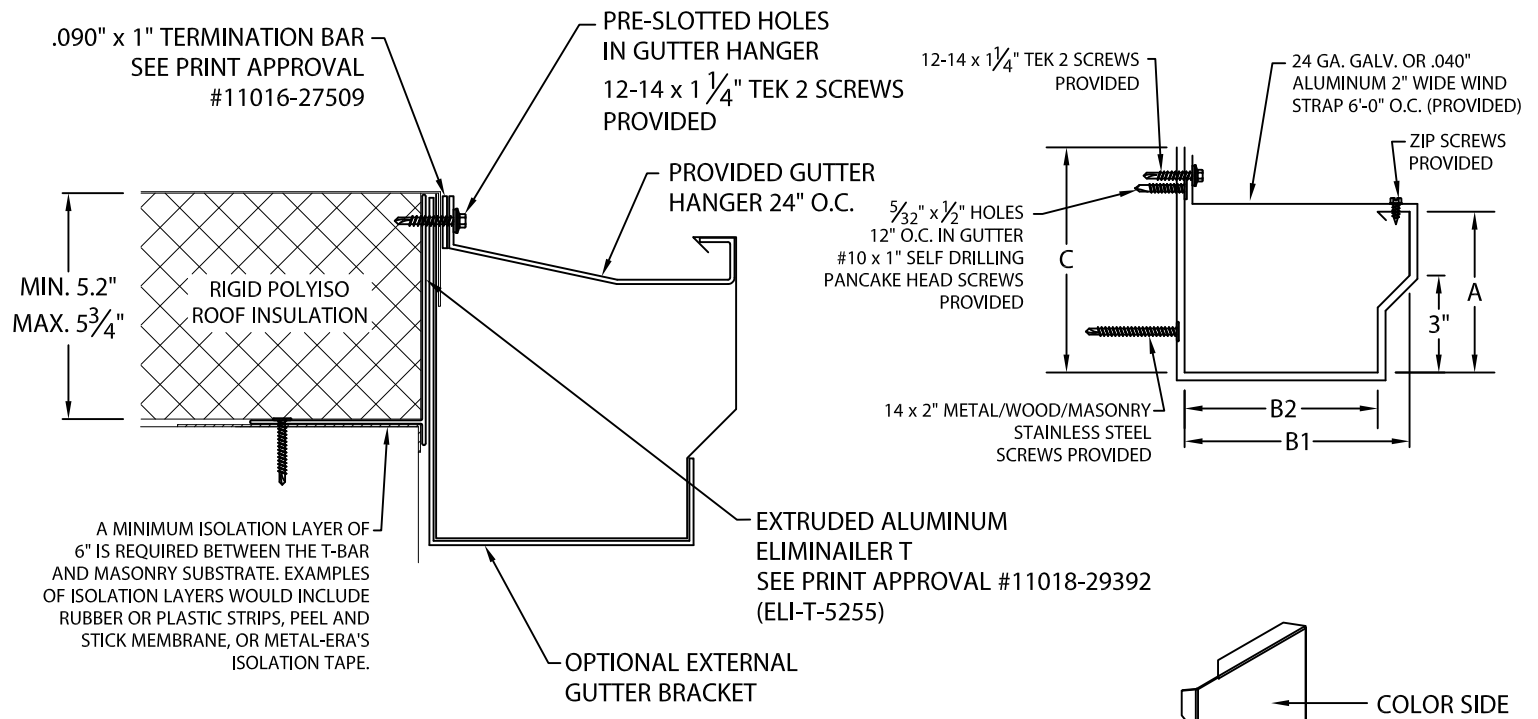

PRODUCT ID #	C	B1	B2	A
<input type="checkbox"/> T-IGG1-C8	8"	7"	6"	7"
<input type="checkbox"/> T-IGG1-C9	9"	8"	7"	8"

**NOTES:**

- MAXIMUM DOWNSPOUT DIMENSION NOT TO EXCEED "B2" MINUS 9/16".
- 6" WIDE SPLICE PLATES PROVIDED.
- 1/8" STAINLESS STEEL POP RIVETS PROVIDED.
- UNLESS OTHERWISE NOTED, FABRICATION OF MITERS ARE FURNISHED STANDARD UTILIZING A NON-PENETRATING QUICKLOCK JOINT, THEN FACTORY SEALED WATERTIGHT.
- WELDED ACCESSORIES REQUIRE A MINIMUM MATERIAL THICKNESS OF .050".

**MATERIAL:**

\_\_\_ 24 GA. GALVANIZED STEEL

\_\_\_ .040" ALUMINIUM      COLOR: \_\_\_\_\_

\_\_\_ .050" ALUMINIUM

\_\_\_ .063" ALUMINIUM      FINISH: \_\_\_\_\_

\_\_\_ OTHER \_\_\_\_\_

Fabrication will proceed only after receipt of signed print approval.

**Print Approval:**

Architect and/or contractor shall verify all dimensions, sizes and quantities. All products to be installed in strict accordance with Metal-Era's printed instructions.

Approved by: \_\_\_\_\_

Date: \_\_\_\_\_

**QUANTITIES:**

\_\_\_\_\_ LINEAL FEET 12'-0" LENGTHS

\_\_\_\_\_ OUTSIDE MITERS @ 90°

\_\_\_\_\_ INSIDE MITERS @ 90°

\_\_\_\_\_ RIGHT ENDCAPS

\_\_\_\_\_ LEFT ENDCAPS

\_\_\_\_\_ EXPANSION JOINTS STYLE "1"

\_\_\_\_\_ EXPANSION JOINTS STYLE "2"

SPECIFY MITER TYPE:

WELDED

QUICKLOCK

FOR NON-90 MITERS SEE PRINT APPROVAL #11012-10010

**PROJECT:**

**ARCHITECT:**

**ROOFING CONTRACTOR:**

**REPRESENTATIVE/DISTRIBUTOR:**

Corporate Offices, Manufacturing  
1600 Airport Road; Waukesha, WI 53188  
Phone: 800-558-2162  
Fax: 800-373-9156  
www.metalera.com



DATE: 05/20/19

DRN BY: ZS

CKD BY: JAI

SHT.# \_\_\_\_ OF \_\_\_\_

DWG# 11012-29716

**B**

# ELIMINAILER®-T

FOR USE WITH MASONRY WALL, 5.2", 4" FLANGE VERSION

U.S. PATENT # 9,878,023 B1

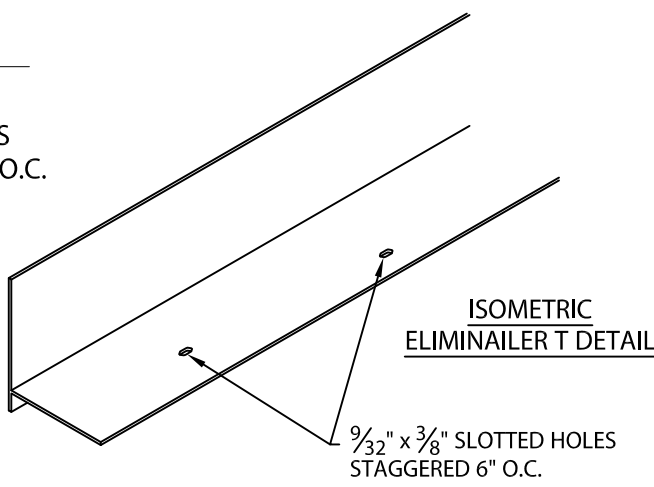
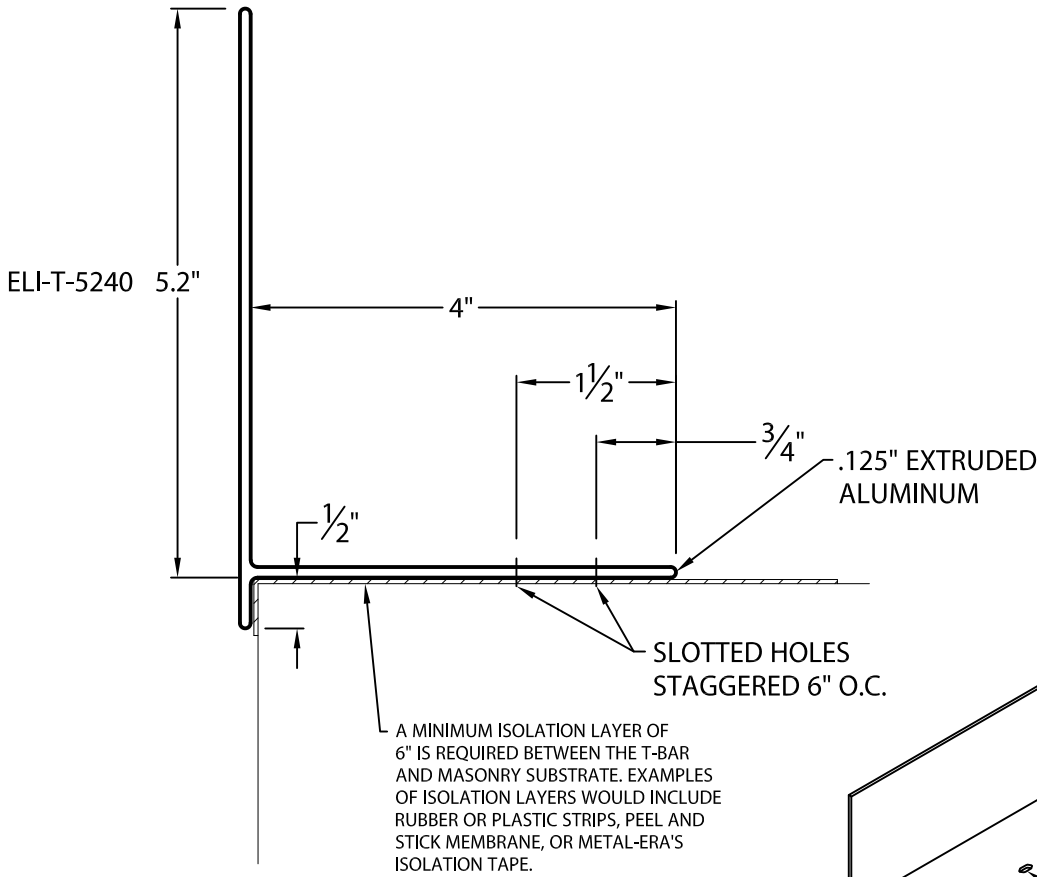

Fabrication will proceed only after receipt of signed print approval.

## Print Approval:

Architect and/or contractor shall verify all dimensions, sizes and quantities. All products to be installed in strict accordance with Metal-Era's printed instructions.

Approved by: \_\_\_\_\_  
Date: \_\_\_\_\_

PLEASE INDICATE SUBSTRATE (IF SUBSTRATE INFORMATION IS NOT GIVEN, CONCRETE WALL FASTENERS WILL BE PROVIDED)

- CONCRETE WALL (3000 PSI CONCRETE):  
#14 x 1 1/4" FASTENERS PROVIDED
- CMU WALL (1500 PSI):  
1/4" x 1 1/2" SPIKE FASTENERS PROVIDED

### QUANTITIES:

\_\_\_\_\_ LINEAL FEET 12'-0" LENGTHS  
\_\_\_\_\_ ROLLS ISOLATION TAPE 6" WIDE (180 FT PER ROLL)

PROJECT: \_\_\_\_\_  
ARCHITECT: \_\_\_\_\_  
ROOFING CONTRACTOR: \_\_\_\_\_  
REPRESENTATIVE/DISTRIBUTOR: \_\_\_\_\_

Corporate Offices, Manufacturing  
1600 Airport Road; Waukesha, WI 53188  
Phone: 800-558-2162  
Fax: 800-373-9156  
www.metalera.com



DATE: 07/30/18  
DRN BY: JJC  
CKD BY: SAK

SHT.# \_\_\_\_ OF \_\_\_\_  
DWG# 11018-29392

A

# TERMINATION BAR

CB-90

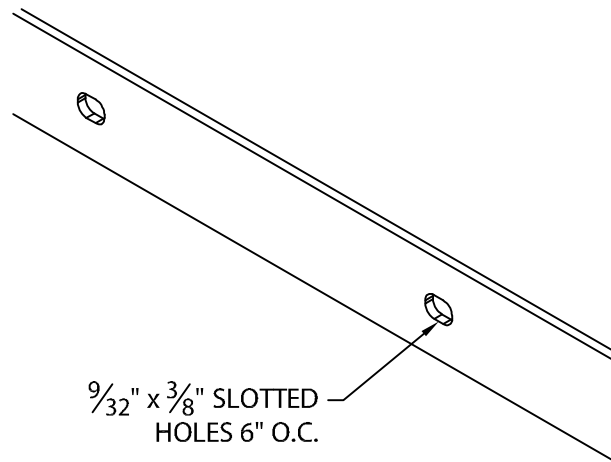
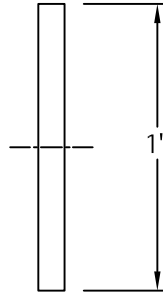

Fabrication will proceed only after receipt of signed print approval.

## Print Approval:

Architect and/or contractor shall verify all dimensions, sizes and quantities. All products to be installed in strict accordance with Metal-Era's printed instructions.

Approved by: \_\_\_\_\_

Date: \_\_\_\_\_

## MATERIAL:

.090" ALUMINUM

## QUANTITIES:

\_\_\_\_\_ LINEAL FEET 12'-0" LENGTHS

PROJECT:

ARCHITECT:

ROOFING CONTRACTOR:

REPRESENTATIVE/DISTRIBUTOR:

Corporate Offices, Manufacturing  
1600 Airport Road; Waukesha, WI 53188  
Phone: 800-558-2162  
Fax: 800-373-9156  
www.metalera.com



DATE: 11/09/17

DRN BY: JJC

CKD BY: SAK

SHT.# \_\_\_\_ OF \_\_\_\_

DWG# 11016-27509

**A**